

AIRMAN

PG

INSTRUCTION MANUAL

ENGINE COMPRESSOR

PDS185L-5E1

Please be sure to read this manual
before using this machine.

HOKUETSU INDUSTRIES CO., LTD.

Preface / Table of Contents

Thank you for having selected our "AIRMAN" product.

- ◆ Keep this manual at hand to refer to it always when necessary.
- ◆ When this manual is missing or damaged, order it from our office or your nearest dealer. Make sure that the manual is included with the machine when it is handed over to another user.
- ◆ The contents of this manual may differ from the machine because of design changes. If anything is unclear, please contact our office or your nearest dealer for clarification.

— Table of Contents —



1. Part Names	1-1
1.1 Internal Components and Part Names	1-1
2. Installation	2-1
2.1 Transportation	2-1
2.2 Installation conditions	2-3
3. Operation	3-1
3.1 Operation Panel	3-1
3.2 Lubricating oil·Coolant·Fuel	3-2
3.3 Check before starting unit	3-4
3.4 Operation	3-12
3.5 Capacity Control Device	3-17
3.6 DPF regeneration	3-20
3.7 Emergency Stop	3-22
4. Failure cause and measures	4-1
4.1 Indicator lamp and Warning / Emergency display	4-1
4.2 Troubleshooting	4-3
4.3 Adjustment of Various data	4-6
5. Periodic Inspection/Maintenance	5-1
5.1 Important Items at Periodic Inspection and Maintenance or after Maintenance	5-1
5.2 Periodic Inspection List	5-3
5.3 Periodic Replacement of Parts	5-5
5.4 Maintenance Items	5-6
6. Storage and Disposal	6-1
6.1 Preparation for Long-term Storage	6-1
6.2 Disposal of Product	6-1
7. Specifications	7-1
7.1 Specifications	7-1
7.2 Exterior drawing	7-2
7.3 Wiring Diagram	7-4
7.4 Piping Diagram	7-5
8. Emission System Warranty	8-1

Safety

This section explains safety cautions for safety work for operation, inspection, maintenance, installation, movement and transportation. Read these safety requirements carefully and fully understand the contents before starting the machine.

For your better understanding of the precautions in this manual and on this machine, safety precautions are classified into “DANGER”, “WARNING” and “CAUTION” message with a warning symbol  marked, according to the degree of hazards.

When one of these messages is found, please take preventative safety measures and carry out “SAFETY OPERATION AND PROPER MAINTENANCE OF THE MACHINE”.

 DANGER	DANGER indicates an imminently hazardous situation which, if not avoided, will result in death or serious injury.
 WARNING	WARNING indicates a potentially hazardous situation which, if not avoided, could result in death or serious injury.
 CAUTION	CAUTION indicates a potentially hazardous situation which, if not avoided, may result in minor or moderate injury. It may also be used to alert against unsafe practices.
IMPORTANT	IMPORTANT indicates important caution messages for the performance or durability of the machine, which has no concern to injury or accident of or to a human body.

This manual does not describe all safety items. We, therefore, advise you to pay special attention to all items (even though they may not be described in the manual) for your safety.

PROPOSITION 65 WARNING

 WARNING
<p>Breathing engine exhaust exposes you to chemicals known to the State of California to cause cancer and birth defects or other reproductive harm.</p> <ul style="list-style-type: none"> ● Always start and operate the engine in a well-ventilated area. ● If in an enclosed area, vent the exhaust system. ● Do not modify or tamper with the exhaust system. ● Do not idle the engine except as necessary <p>For more information, go to www.P65warnings.ca.gov/diesel</p>

Safety

- ◆ Please tell us a MODEL /SER.No. on the plate of the machine when you make an inquiry.
A plate stamped with the model and serial number is attached to side of the machine.

PORTABLE COMPRESSOR	
MODEL	<input type="text"/>
SER. NO.	<input type="text"/>
NORMAL OPERATING PRESSURE	<input type="text"/> MPa
NET DRY MASS	<input type="text"/> kg
OPERATING MASS	<input type="text"/> kg
HOKUETSU INDUSTRIES CO., LTD. MADE IN JAPAN 39103 10811	

※ Each illustrated figure (Fig.) has a number (for instance, A130375) at the right bottom. This number is not a part number, it is an internal reference number.

A130375

Safety

[Safety Warning Labels]

Following labels are attached to the machine.

Keep them clean at all times. If they are damaged or missing, immediately place an order with your nearest dealer for replacement. Part numbers are indicated on the lower right corner of the label.

Adhere a new one to the original location.

1



CAUTION

PREVENT FIRE ACCIDENT

Periodically check compressor oil and oil separator surely. Failure of this fire accident.

39176 69700

2



WARNING

BEWARE OF HIGH PRESSURE AIR BLOW OUT

Oil supply and/or maintenance jobs with residual pressure left in tank are very dangerous. So release the residual pressure first.

39176 69800

3

DANGER EXPLOSIVE GASES
Cigarettes, flames or sparks could cause battery to explode. Always shield eyes and face from battery. Do not charge or use booster cables or adjust post connections without proper instruction and training.
KEEP VENT CAPS TIGHT AND LEVEL
POISON CAUSES SEVERE BURNS
Contains sulfuric acid. Avoid contact with skin, eyes or clothing. In event of accident flush with water and call a physician immediately.
KEEP OUT OF REACH OF CHILDREN

39176 50000

5



LIFTING BAIL

39176 69300

4



FLAMMABLES

DIESEL FUEL

EPA REGULATION

ULTRA LOW SULFOR FUEL ONLY.
DIESEL A TRES FAIBLE TENEUR EN SOUFRE UNIQUEMENT.

39178 22031

6



CAUTION

PREVENT BURNING ACCIDENT

Do not open radiator cap while it is still hot.

39176 69600

7



CAUTION

PREVENT BURNING ACCIDENT

When work is required near hot parts, wait for the parts to cool down fully before starting work.

39176 69500

8



WARNING

BEWARE OF ENTANGLEMENT

Keep your hands AWAY from moving parts such as V-belts, pulleys etc.. Entanglement in them can cause serious injury.

39176 73800

9



WARNING

BEWARE OF ENTANGLEMENT

Keep your hands AWAY from fan during operation. Entanglement in the fan can cause serious injury.

39176 73500

10



WARNING

BEWARE OF EXHAUST GASES

When you operate machine INDOORS or in TUNNEL, provide good ventilation. Poor ventilation can cause fatal accident.

39176 73300

11



DANGER

DO NOT BREATHE COMPRESSED AIR

Do not use this compressed air for breathing air because it can cause fatal accidents. Never breathe it.

39176 73600

12



WARNING

BEWARE OF RESIDUAL PRESSURE

Release residual pressure inside pipings and hoses and then disconnect them. Disconnection with residual pressure still left can cause serious injury.

39176 73400

13

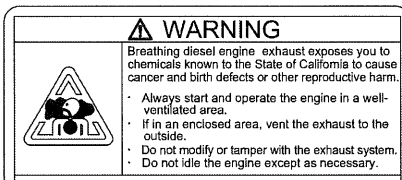

WARNING

Breathing diesel engine exhaust exposes you to chemicals known to the State of California to cause cancer and birth defects or other reproductive harm.

- Always start and operate the engine in a well-ventilated area.
- If in an enclosed area, vent the exhaust to the outside.
- Do not modify or tamper with the exhaust system.
- Do not idle the engine except as necessary.

For more information go www.P65warnings.ca.gov/diesel

39178 67840

Safety

- The pasting position of safety warning labels is as follows.

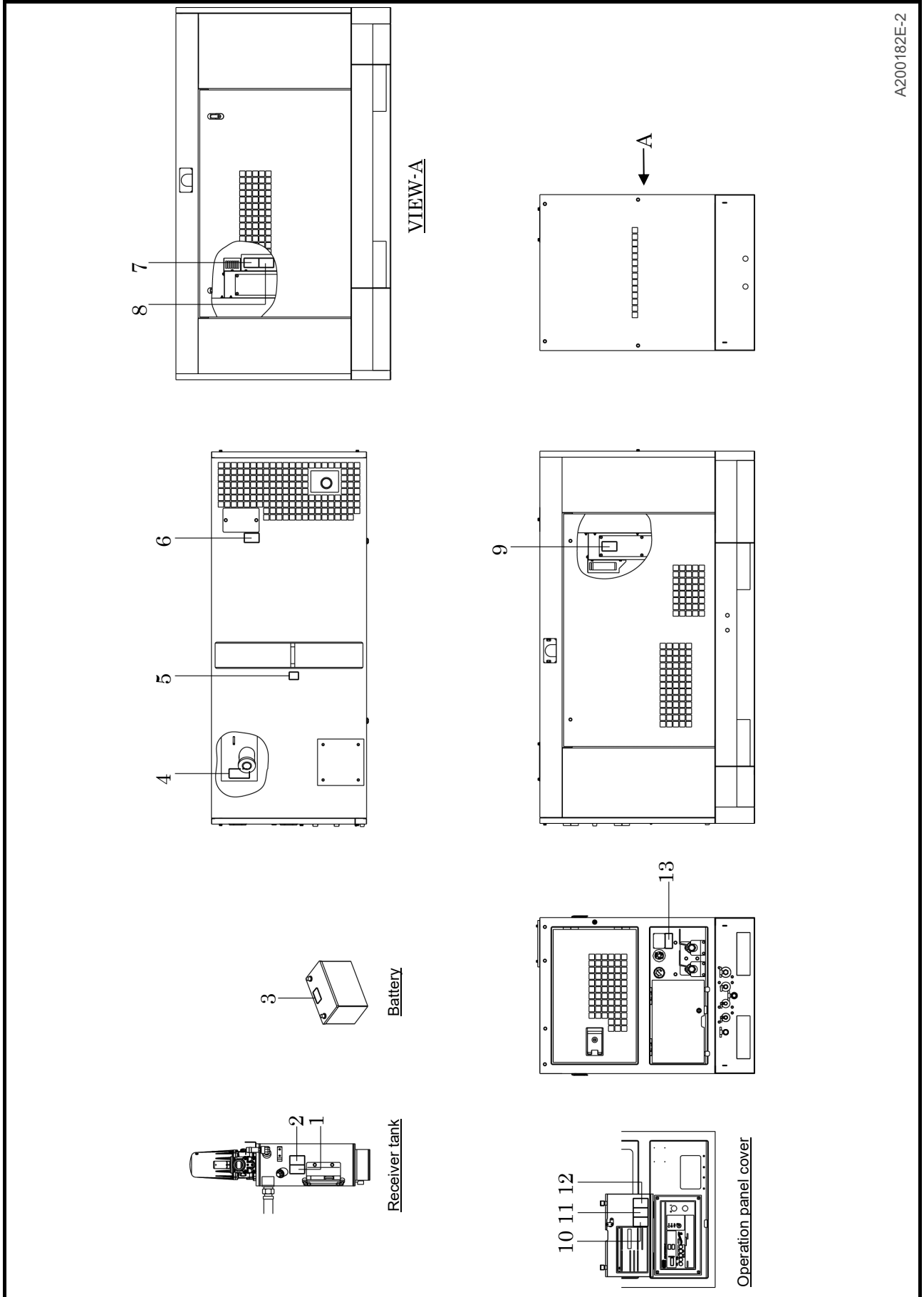

A200182E-2

Safety

DANGER

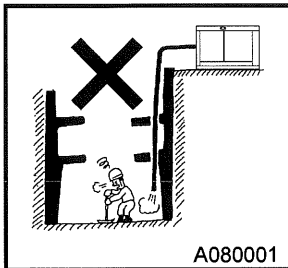
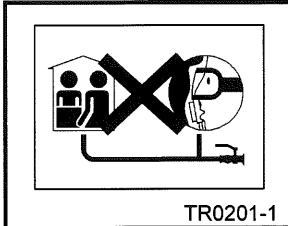

- Compressed air from this machine contains poisonous materials. Absorption of the compressed air can cause serious injury. Never provide this compressed air for human respiration.
- This machine is not designed to be used for working chambers pressurized by compressed air such as respiratory air provided to persons working inside wells and tunnels such as pneumatic engineering method and pneumatic caisson method. Should this machine stop operation due to trouble, it can cause death and serious injury to the working persons. Refrain from using the compressed air for such pneumatic engineering method or pneumatic caisson method.

WARNING

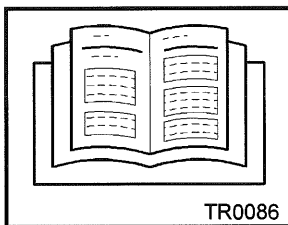

- Read each instruction plate which is displayed in the manual or on the machine carefully, understand its content and follow the indications thereof.
- Do not modify the machine without prior approval. The safety may be compromised, functions may be deteriorated, or the machine life may be shortened.
- Never use the machine for the purpose of compression of gases other than air, or as a vacuum pump. Otherwise, serious accidents may occur.

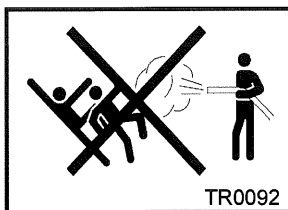

- Never blow compressed air directly at people. Scattered impurities, dust, or foreign objects in the compressed air may cause skin and eyes to be seriously injured.
- As compressed air contains toxic gas etc., compressed air should not be used to be blown or sprayed against food etc.

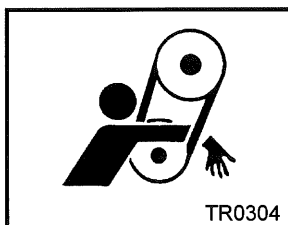

- Keep hands away from the rotating machinery or belts during operation.

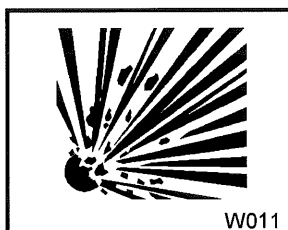

- When you refill the separator receiver tank with compressor oil, stop the engine, and make sure that the pressure gauge indicates 0psi(0bar) and there is no residual pressure in it, and then gradually loosen the oil filler cap for refilling oil.
Note residual pressure in the separator receiver tank could force both extremely hot compressed air and oil to jet out and you may be scalded or seriously injured.

Safety

WARNING



- When cleaning dust accumulated in such devices as the air-filter, by blowing compressed air, wear safety glasses, etc. to protect your eyes.

CAUTION

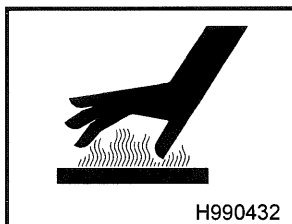

- Be sure to stop the engine, and let the coolant water sufficiently cool down before draining it.
- If the drain valve is opened before the coolant water is cool enough, hot scalding water could jet out, causing burns.

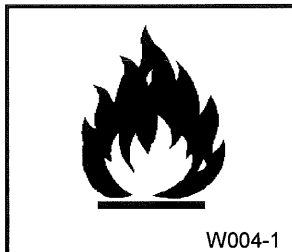

- Be sure to perform the periodic checks of compressor oil and oil separator element.
- Neglecting checks could cause overheat of the oil, resulting in a fire.

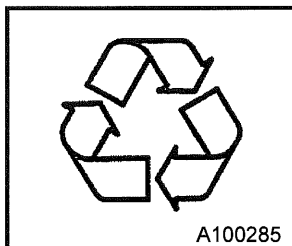

- Waste liquid from the machine contains harmful material. Do not discharge it onto the ground or into the river, lake or sea. Such material will contaminate the environment.
- Be sure to use a container to hold the waste liquid from the machine.
- Be sure to follow the designated regulations when disposing of oil, fuel, coolant (antifreeze), filter, battery or other harmful materials.

- The engine of this machine and electrical parts many electronic devices have been installed. If you perform welding work on this machine, first remove the connector of the electronic control equipment (specifically the ECM). Application of excessive current to electronic controls can cause equipment malfunction.

1. Part Names

1.1 Internal Components and Part Names

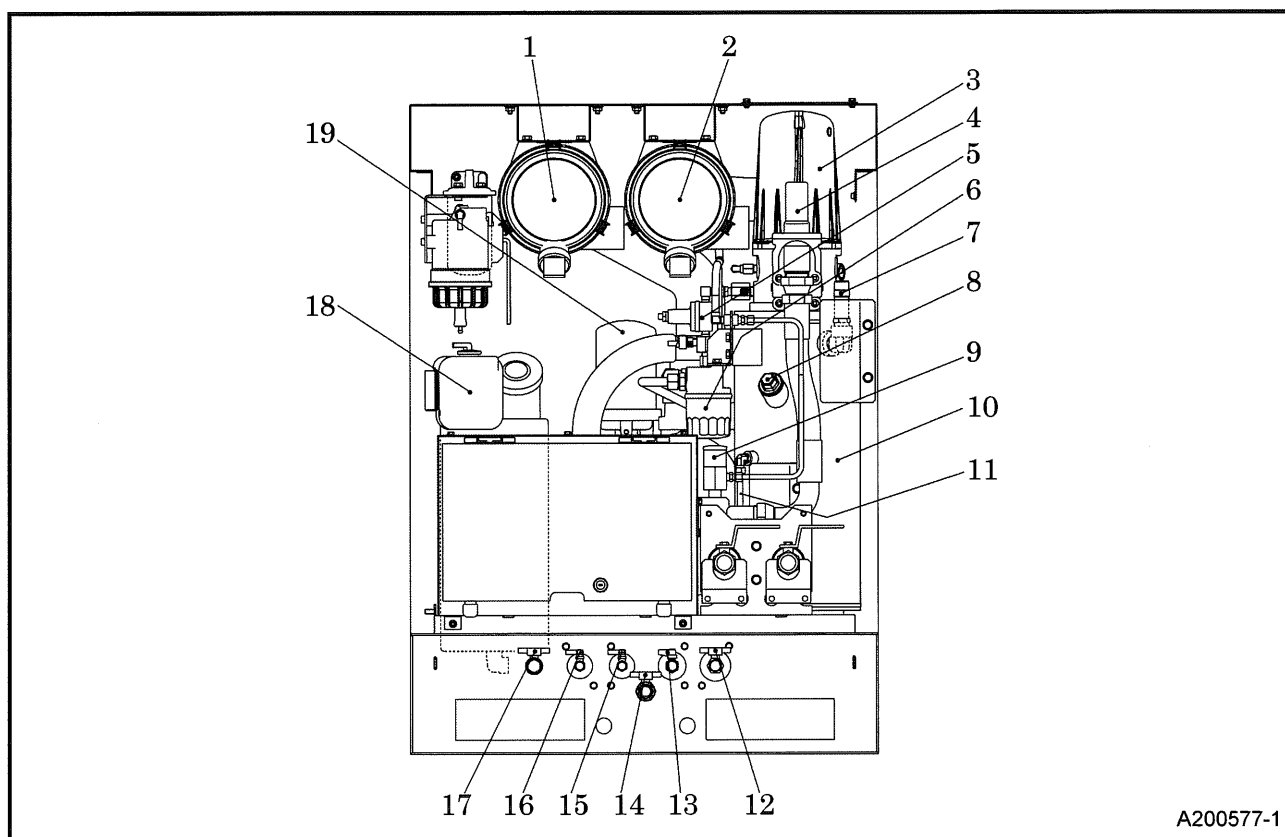

A200577-1

No.	Description	Function
1	Air filter (For compressor air-end)	Filtering device for filtering dust floating in intake air.
2	Air filter (For engine)	Filtering device for filtering dust floating in intake air.
3	Oil separator	For separating oil mist mixed in compressed air.
4	Pressure control valve	For keeping the pressure in receiver tank constantly higher than a certain level in the system.
5	Pressure regulator	For maintaining the set pressure of the compressor.
6	Engine oil filter	Device that filters engine oil.
7	Safety valve	For releasing compressed air to the atmosphere when the pressure rises higher than the rated pressure in the system.
8	Compressor oil filler port	For supplying and replenishing compressor oil.
9	Engine oil filler port	Port for supplying / replenishing engine oil.
	Engine oil level gauge	For checking engine oil level.
10	Separator receiver tank	For separating air and oil from compressed air in the system.
11	Compressor oil level gauge	For checking quantity and impurity of compressor oil.
12	Engine oil drain valve	For draining engine oil for replacement of it and for maintenance.
13	Oil cooler drain valve	For draining compressor oil out of oil cooler and oil lines.
14	Oil fence drain valve	For discharging drain collected in oil fence.
15	Radiator drain valve	For draining engine coolant.
16	Fuel tank drain valve	For draining condensates from fuel tank.
17	Separator receiver tank drain valve	From this portion where condensate is drained out of separator-receiver tank.
18	Reserve tank	Tank for verifying & replenishing coolant
19	Compressor oil filter	For filtering compressor oil circulating in the system.

1. Part Names

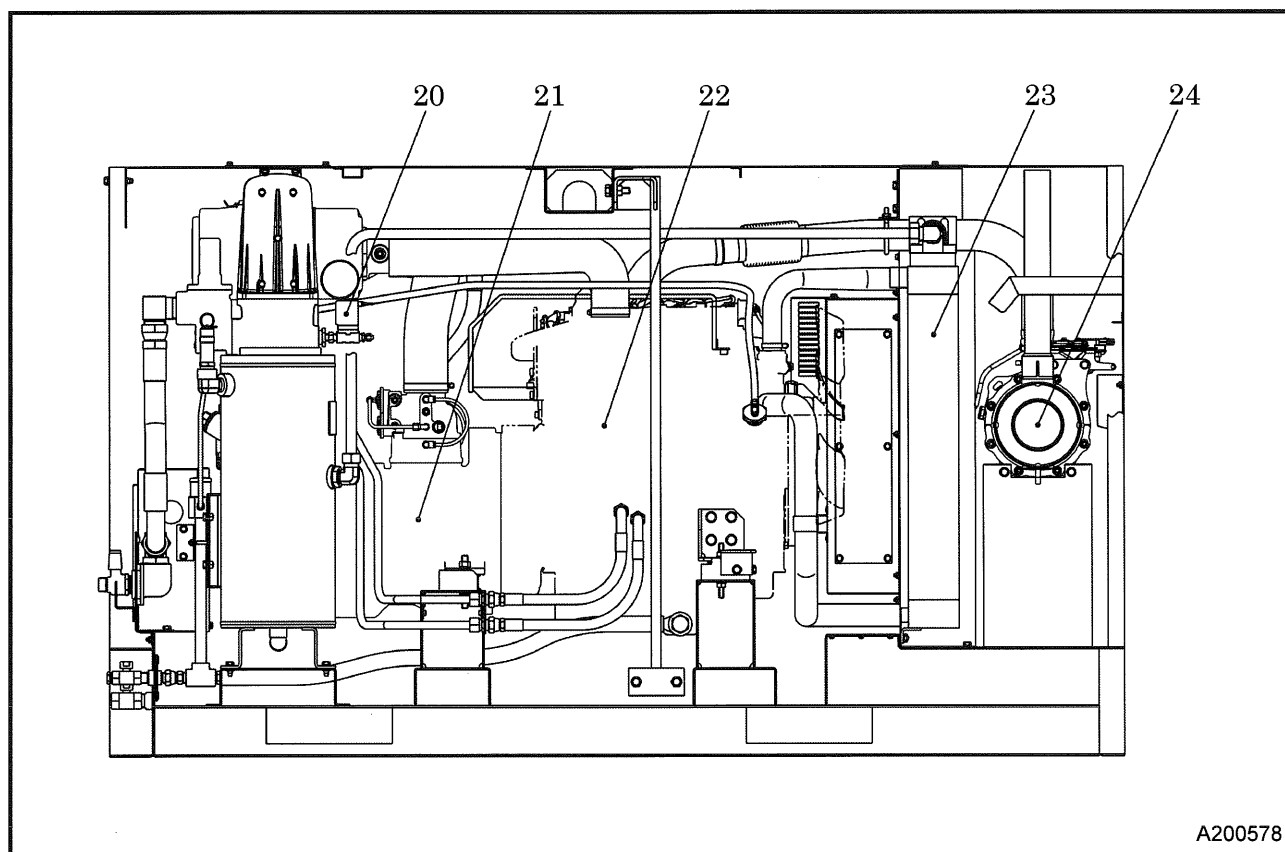

A200578

No.	Description	Function
20	Solenoid valve for starting unload	For reducing load at start-up.
21	Compressor air-end	For compressing air in the system.
22	Engine	For driving the compressor.
23	Oil cooler	For cooling compressor oil circulating in the system.
24	DPF (Diesel particulate filter)	Apparatus for removing harmful components contained in the exhaust gas.

1. Part Names

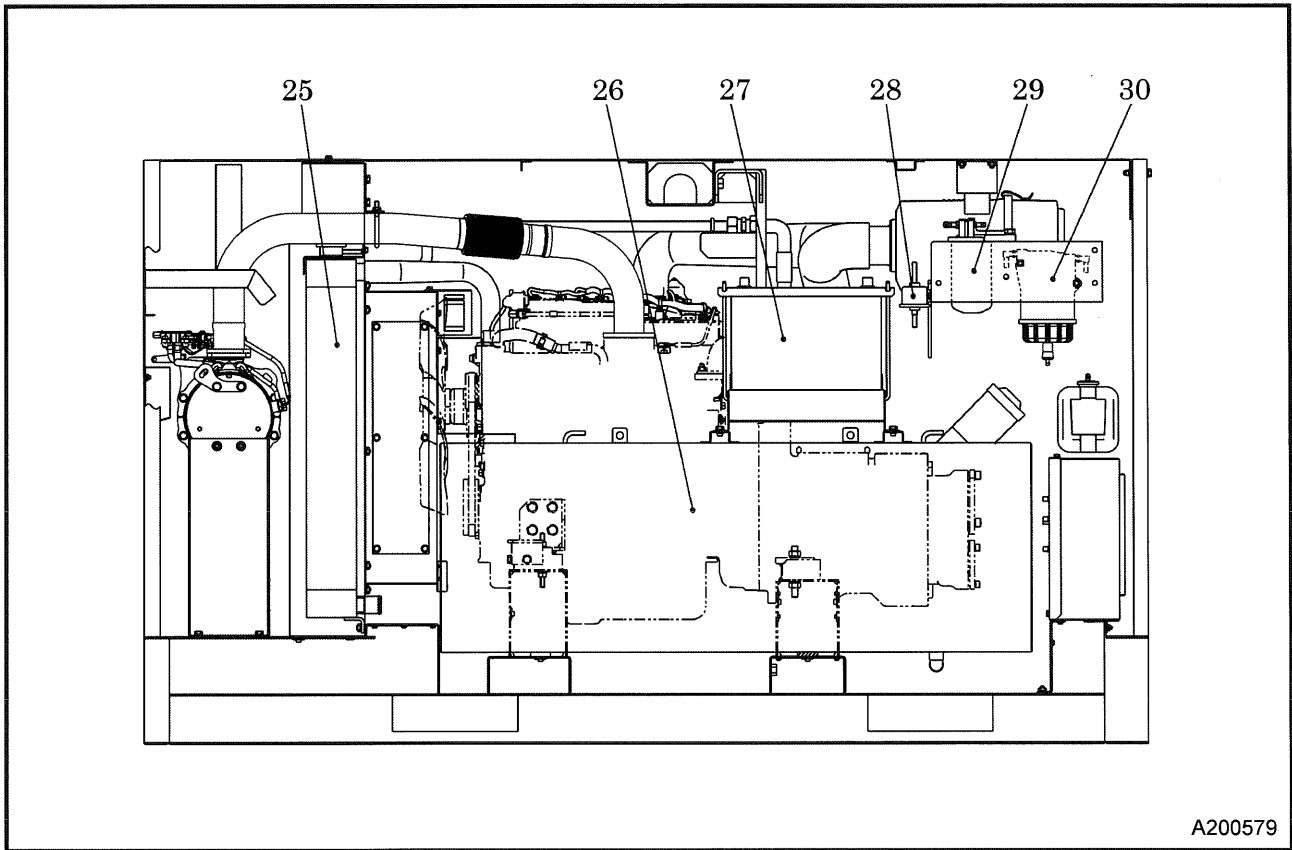

A200579

No.	Description	Function
25	Radiator	Device that cools the engine coolant.
26	Fuel tank	Vessel for storing fuel.
27	Battery	Power source to start the engine.
28	Air bleeding electromagnetic pump	Device that automatically bleeds air from the fuel lines.
29	Main fuel filter	Device that filters foreign matter & particulate mixed in fuel.
30	Fuel pre-filter	For filtering larger dust, water, etc., from fuel.

2. Installation

2.1 Transportation

When loading and unloading the machine, be sure to use the lifting bail provided on the center of the machine top.

2.1.1 Lifting up

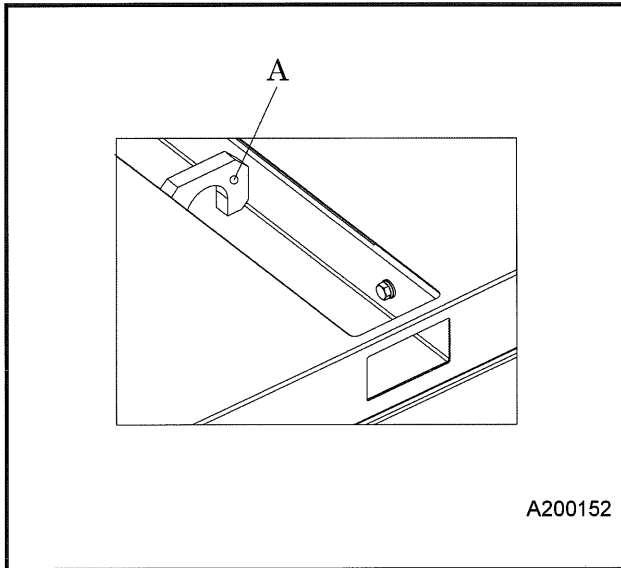

<Procedure>

1. Before lifting the machine up, make sure to check the lifting bail [A] for any crack or loosened bolts.
 2. Connect the hook of the crane or shackle with lifting bail eye fitted at the top center of the machine, and make sure that there is no person standing around the machine. Then perform the hoisting operation.
- Select a truck or a crane with a capacity sufficient for the size and weight of the machine by referring to the values shown in Chapter 7 "Specifications" of the manual.
 - Cranes should only be operated by qualified personnel.

2.1.2 Mounting the machine on the truck bed

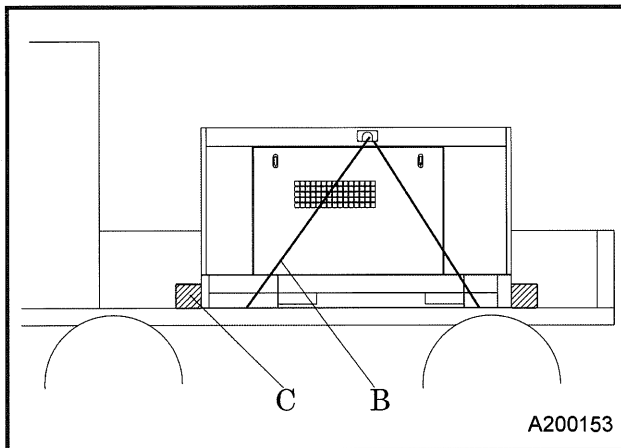

<Procedure>

- To mount the machine on a truck to move or carry from a work site, attach a rope [B] using the lifting bail [A], and set stoppers [C] on the truck bed.



WARNING

Transportation

- Never get under the machine which is lifted up, because it is very dangerous.
- Never lift the machine which is still in operation, or it could cause critical damage to each component or lead to serious accident.

2. Installation

2.1.3 Moving the machine with a forklift

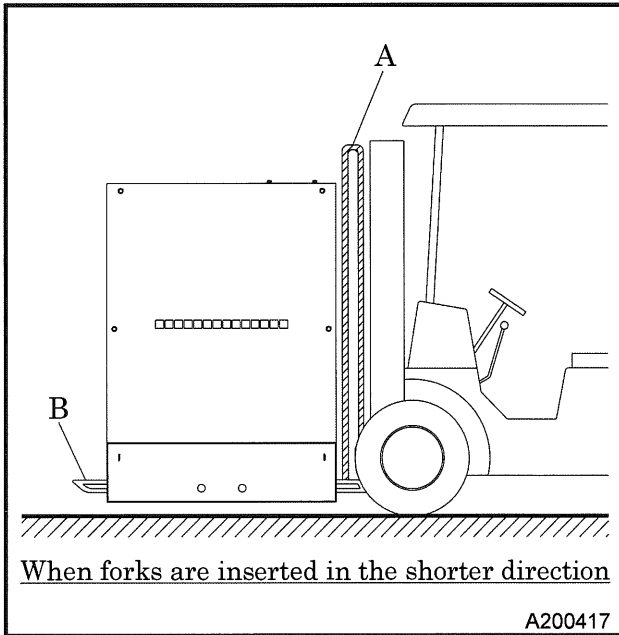

- When a machine is moved or carried from a work site, it can be lifted via a forklift.
- Use cushioning material [A] to ensure that the bonnet is not damaged.
- Confirm that the forks [B] protrude through the fork holes.
- Moving in or carrying out a machine from a work site should be done by qualified personnel only.

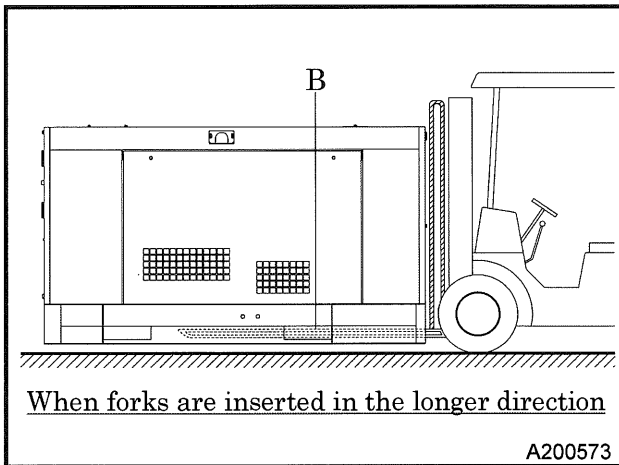

- For safety reasons, forks [B] should be inserted into the hole so that they reach through at least 50% of the length of the machine.

2. Installation

2.2 Installation conditions

The machine has to be parked horizontally on a level place.

- To install this machine on a slope, set it at a right angle to the slope.
- The machine's angle when resting on a slope should be within five degrees of level.
- The machine should be operated in following conditions:
 - Ambient temperature 5°F to 104°F(-15°C ~ +40°C)
 - Humidity Less than 90%
 - Altitude Lower than 4,921ft above sea level
- ※ **If you use the machine not in the conditions stated above, it may causes serious breakdown.**
 - The machine has to be installed in the environment where fresh air is always available, temperature is low and ambient air is dry as much as possible.
 - To prevent the deterioration of cooling capability, make sure to allow for at least five inches of space on either side and at the back of the machine.
 - If more than two machines are placed parallel in operation, keep enough distance so that exhaust air from one machine does not affect the other one.
 - Also, a machine has to be installed in the environment where fresh air is always available.
 - Keep enough space around the machine for inspection and maintenance access.

⚠ WARNING

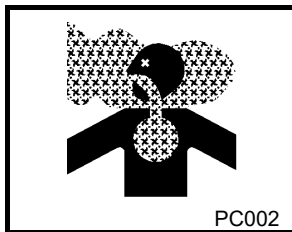

- Exhaust gas can cause death or serious injury upon inhalation. Avoid using the machine in an insufficiently ventilated building or tunnel.
- Do not position the exhaust gas outlet in direction of a person or a house.

2.2.1 How to secure the machine to a truck

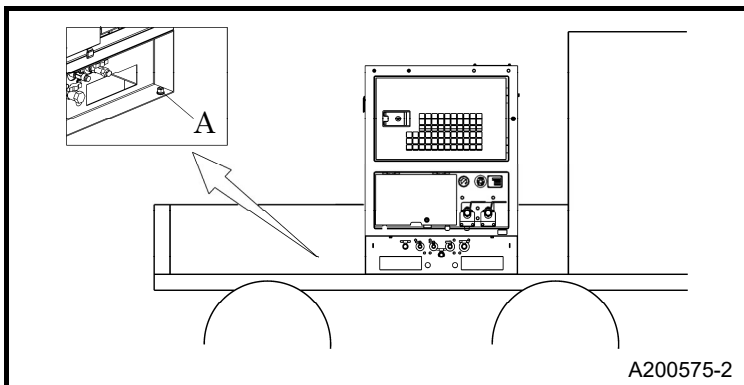

- To place and secure this machine on a truck bed, always use fixing hole [A] on the frame, as shown in the left figure when securing the machine.
- Tightening torque of the bolts : M12(43N·m)

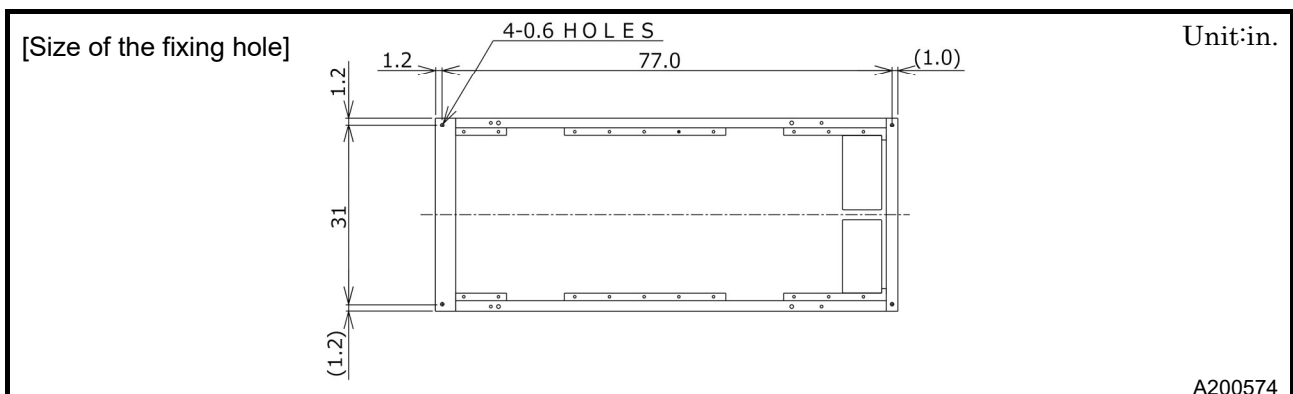

2. Installation

2.2.2 Service valve

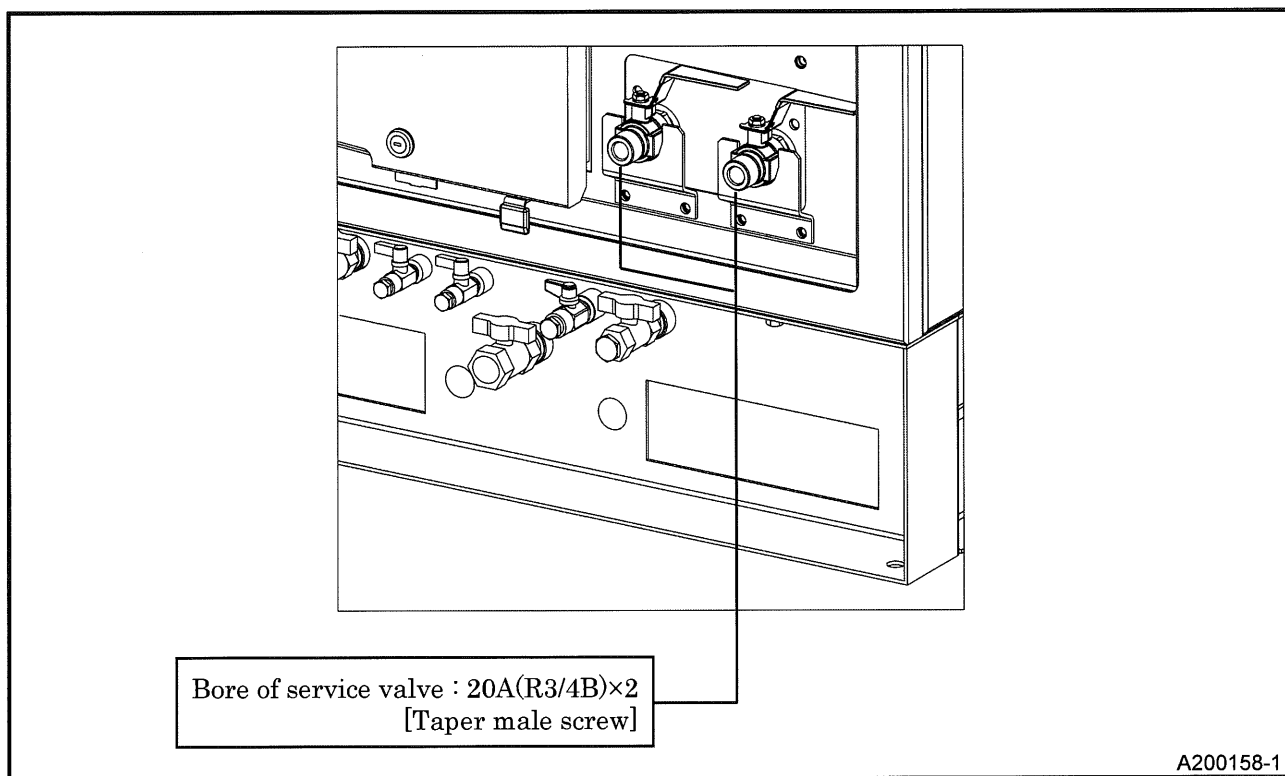

WARNING

Cautions of hose attachment and removal

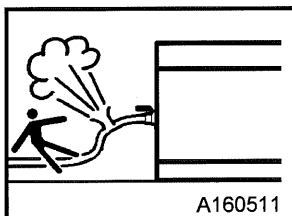
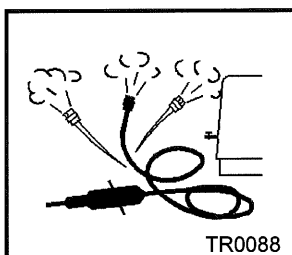

- Piping or the hose from this machine service valve should use what can be borne enough for the safety valve set pressure of this machine.
- Please connect piping or a hose to this machine service valve firmly before operation and during operation.
If the connection is loose, there is a possibility of piping or a hose separating and getting seriously injured.
- Please remove after closing the service valve and relieving remaining pressure. If pressure remains, there is a possibility of the hose whipping, causing damage and possibly injury.
- In order to use it safely, please read the handling of the work tools often used.

2. Installation



CAUTION

Operation with discharge port (compressed air supply port) opened is prohibited

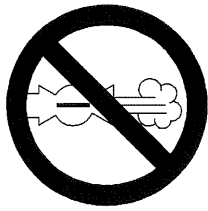

D003

- Do not operate the machine with service valves and relief valve open unless air hoses and/or pipes are connected. High-pressurized air blows out and its air pressure could cause injury to the people nearby.
- When the machine has to be unavoidably temporarily operated with its port open, be sure to mount a silencer to reduce noise and wear protective materials such as earplugs to prevent damage to hearing.

3. Operation

3.1 Operation Panel

Each display of the operation panel is illustrated as follows.

Read and fully understand the explanations and be sure to operate safely:

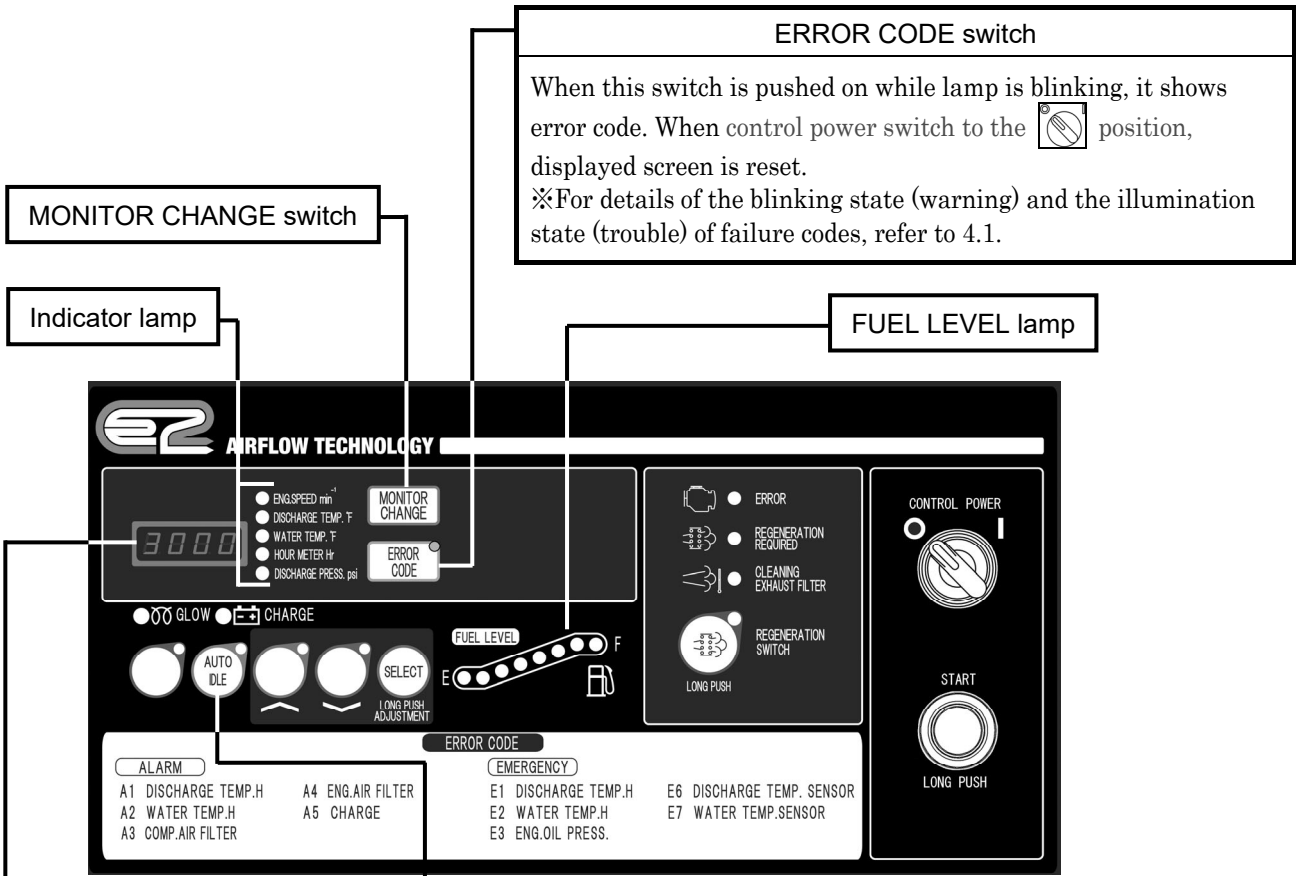

A230206

AUTO IDLE switch

The switch is used for minimizing fuel consumption at no-load operation. (It functions when the lamp goes on.)

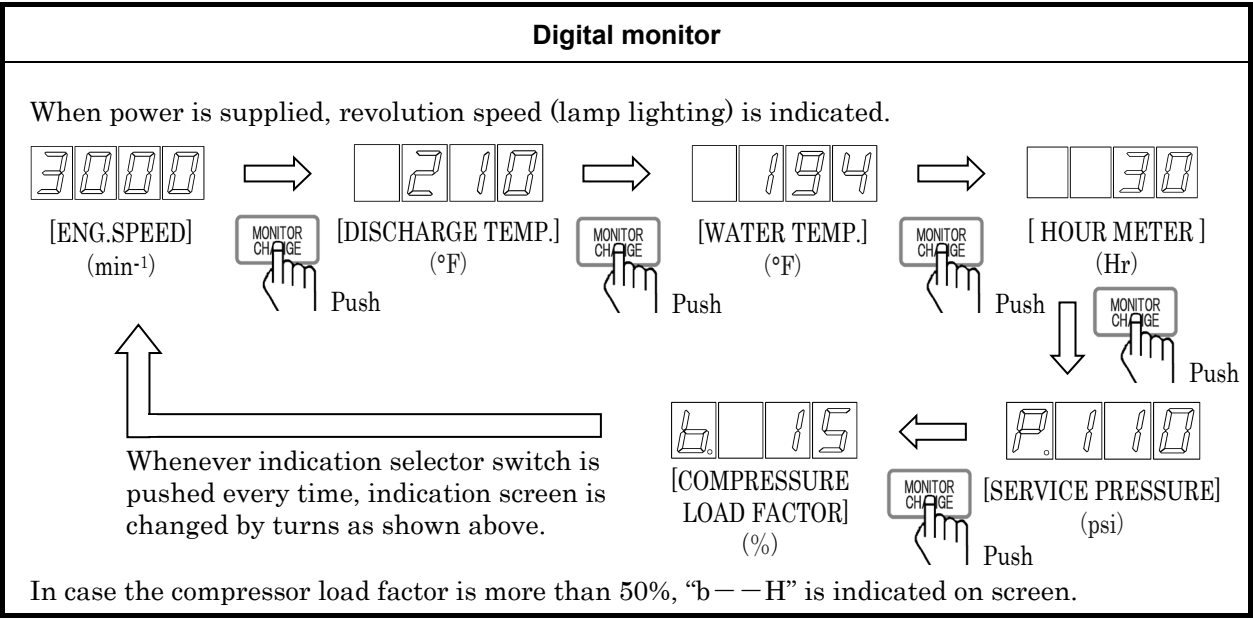

3. Operation

3.2 Lubricant·Coolant·Fuel

3.2.1 Engine oil

Use engine oil recommended by us. (Using engine oil with poor quality may shorten the life of the engine)

Classification	API service classification CJ-4
Viscosity	SAE10W-30 (delivery condition)

IMPORTANT

- Viscosity of engine oil greatly affects startability, performance, oil consumption of the engine, as well as wear of the moving parts. choose appropriate oil based upon the table below according to the outside air temperature.

Ambient temperature range and oil viscosity (SAE)

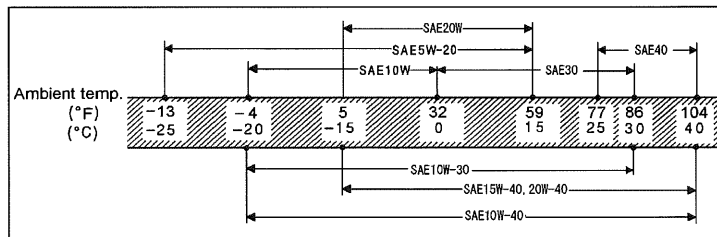

A200331E

- Be sure to use CJ-4 class engine oil or superior class. (Using engine oil with poor quality may shorten the life of the engine).
- When two or more different brands of oil are mixed, its performance can be deteriorated. Do not mix oils.
- Follow the designated regulations to dispose of engine oil.

3.2.2 Compressor oil

Be sure to use recommended oil listed below. Even continuous oil replenishment cannot improve its deteriorated condition. Be sure to change the oil completely at every scheduled interval.

Maker	Brand
MOBIL	MOBIL RARUS SHC 1024
SHELL	SHELL CORENA S4R (VG32)

IMPORTANT

- Mixture of different brands compressor oil could cause an increase of viscosity and make compressor oil sticky. In the worst case, it could cause sticking trouble of compressor air-end “Compressor air-end will not turn”. Also repairing of such air-end needs expensive cost. Therefore, be sure to avoid mixing different brands oil. In case compressor oil brand in use has to be unavoidably changed, it is absolutely necessary to completely clean up the interior of compressor air-end. In such a case, contact “AIRMAN” dealer or us directly.
- Follow the designated regulations to dispose of compressor oil.

3. Operation

3.2.3 Coolant

Use coolant that is a mixture of LLC (antifreeze) and soft water of good quality such as tap water.

IMPORTANT

- If you use water mixed with soil, sand, or dust, or soft water such as well water (ground water), water will easily accumulate in the coolant channels of the engine and radiator, leading to an increase in the coolant temperature.
- Freezing the coolant can damage the engine and radiator. Adjust the LLC (antifreeze) mixing ratio within the range of 35-60% depending on the outside temperature. If the mixing ratio exceeds 60%, the antifreeze effect will decrease. At the time of factory shipment, coolant with a mixing ratio of 35% is filled.

Mixing ratio of LLC (antifreeze) (reference)

Outside temperature (°F)	5	-4	-13	-22	-31	-40	-49
Outside temperature (°C)	-15	-20	-25	-30	-35	-40	-45
Mixing ratio (%)	30	35	40	45	50	55	60

- Use LLC (antifreeze) which conforms to one of such standards : SAE JB13, SAE J1034 and ASTM D3306.
- **Follow the designated regulations to dispose of LLC (antifreeze).**

3.2.4 Fuel

IMPORTANT

- Do not use such diesel fuel having higher sulfur content above 0.0015%(15 ppm)
- Use ultra-low sulfur diesel fuel only for diesel engine.
- Use such diesel fuel which conforms to either EN590 or ASTM D975 standard.
- Do not use kerosene. And never use fuel mixed with kerosene.
- **Follow the designated regulations to dispose of fuel.**

CAUTION

- Diesel fuel is required to meet the following characteristics:
 - Free from even fine dust particulate
 - Appropriate viscosity grade
 - It must have high cetane number. (greater than 45)
 - It must have high fluidity even at low temperature.
 - Carbon residue content in fuel must be a little.

3. Operation

3.3 Check before starting unit

Be sure to check the unit before operation. When any abnormality is found, be sure to repair it before restarting the unit. Be sure to make daily checks before operation. If the unit is operated without prior check and without noticing its abnormality, such operation could cause seizure of components or may even cause fire.

3.3.1 Check engine oil level

Place the machine on level ground when checking the oil level. If you check engine oil level after starting operation, be sure to check it after 10 minutes or more have elapsed since stopping the engine. The engine oil level gauge or "dipstick" is installed behind the operation panel and affixed to the filler cap and can be removed. It is connected to the engine via a hose extending to the operation side for easy access.

<Procedure>

1. Turn the filler cap [A] counter-clockwise, remove the dipstick fully, and dry it with a cloth.
 2. Reinsert the dipstick fully and remove it. The amount of oil is considered normal if it is within the HIGH and LOW marks on the gauge.
 3. If the oil level is below the lower limit, refill the engine oil from the engine oil filler port [B].
- While checking oil level, check also for contamination. If the oil is found dirty, contaminated or should it be changed according to the periodic inspection list, change the oil. **(See 5.4.1)**
 - Excessive engine oil supply could cause engine output degradation. Therefore, never fill more than the HIGH level.

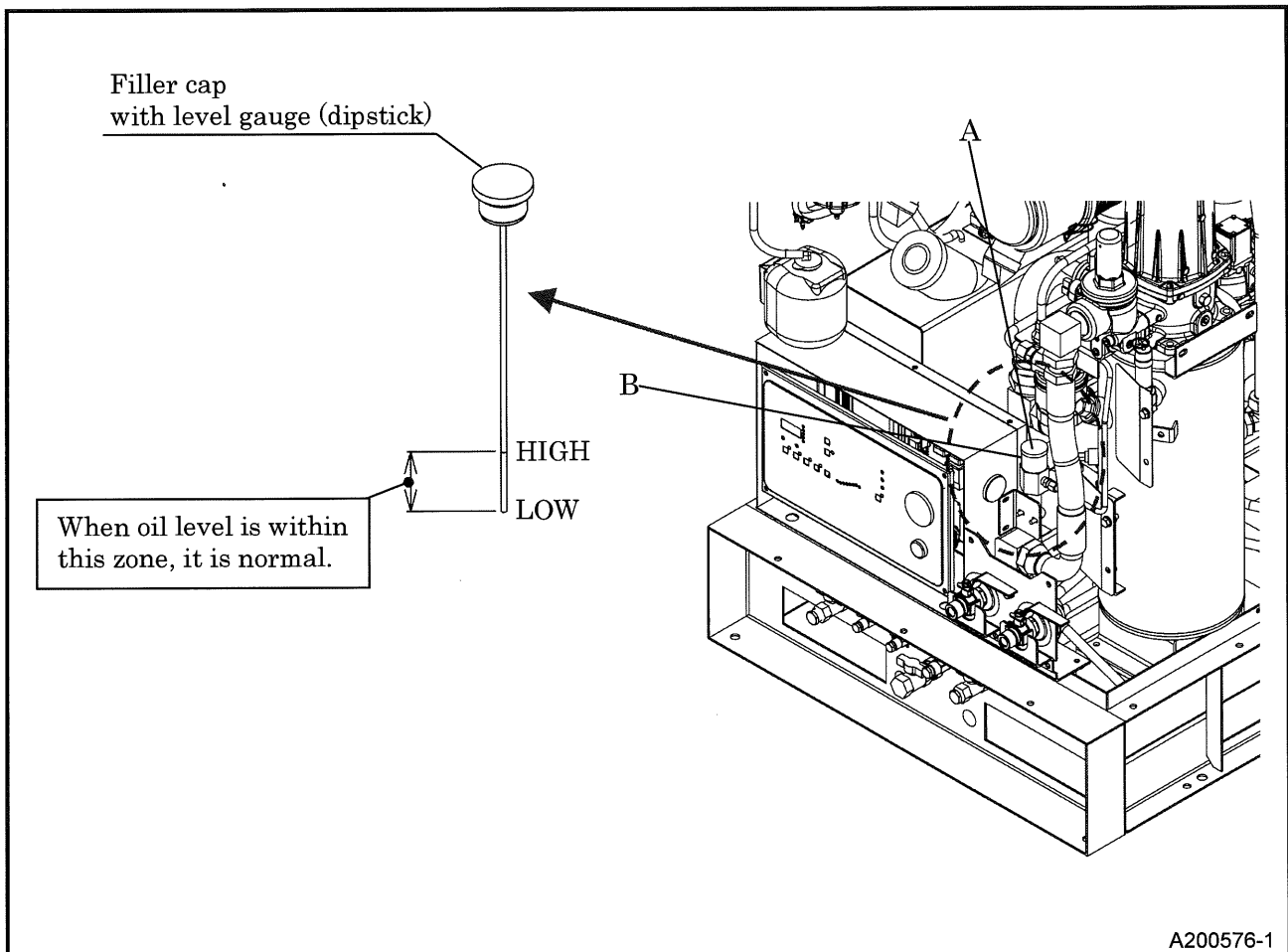

3. Operation

3.3.2 Check coolant level

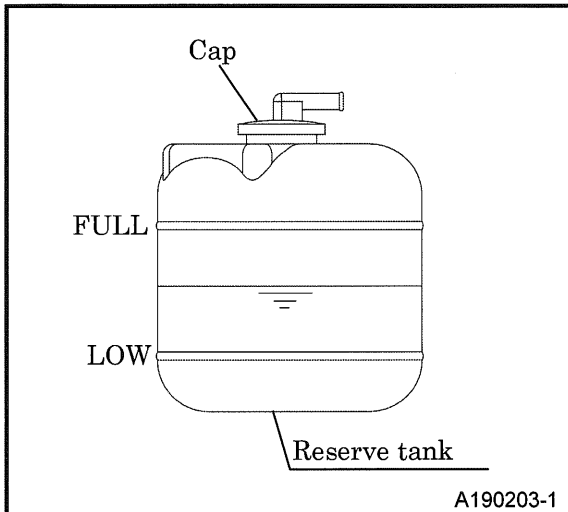

- Verify the coolant level in the reserve tank is above [LOW].
- If the coolant level is lower than [LOW], remove the cap and supply coolant up to the center between [LOW] and [FULL]. If too much coolant is poured into the reserve tank, it may overflow during operation.
- If there is no coolant in the reserve tank, remove the radiator cap and add coolant directly through the radiator fill port. **(See 5.4.17)**

CAUTION

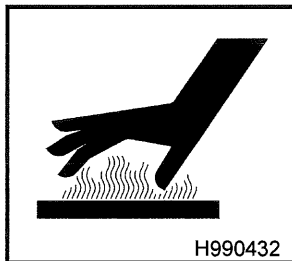

- When removing radiator cap, unfasten it to decrease internal pressure while unlocking first step. After checking internal pressure decreased, unfasten the radiator cap more until second step unlocked. If this procedure is neglected, the inner pressure can blow off the radiator cap, and steam jetting out of the radiator may cause scalding burns.

IMPORTANT

- If the engine is operated with insufficient cooling water, the engine may be damaged.

3. Operation

3.3.3 Check compressor oil level

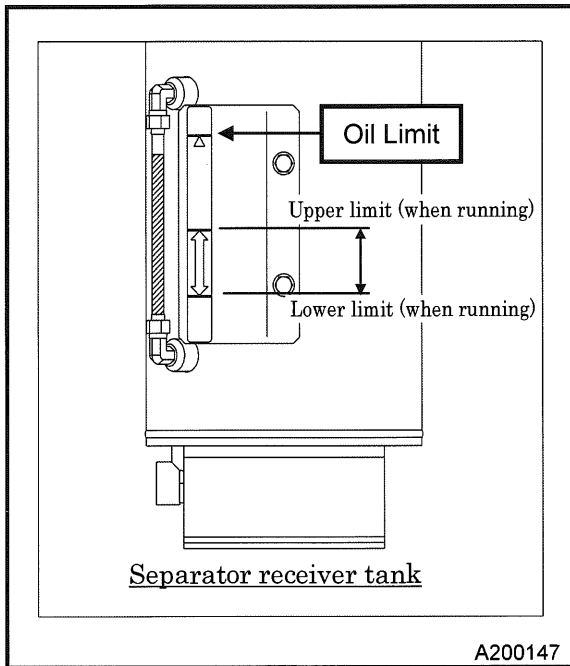

- Unit should be on level before checking compressor oil level.
 - When replenishing compressor oil, make sure that there is no residual pressure in the separator receiver tank and the gauge reads 0 psi (0 bar). Oil should be filled so that the oil level does not fill the gauge and rests below Oil Limit at the top of the sight gauge, but above the Upper Limit mark on the running indicator. The oil level should appear between the Upper limit and Lower limit on the sight gauge when running, as indicated by the label on the receiver tank. **(See 5.4.6)**
- ※ Supply of excessive oil can cause deterioration of oil separation performance and the like.

WARNING

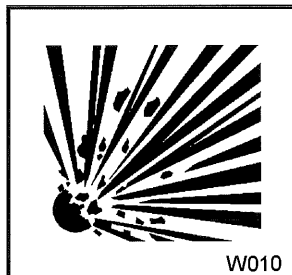

- When you refill the separator receiver tank with compressor oil, stop the engine, and make sure that the pressure gauge indicates 0psi (0bar) and there is no residual pressure in it, and then gradually loosen the oil filler cap for refilling oil.
- Should any residual pressure be left in the separator receiver tank, hot compressed air and hot compressor oil jetting out could cause burning or serious injury to persons nearby.

3. Operation

3.3.4 Drain separator receiver tank

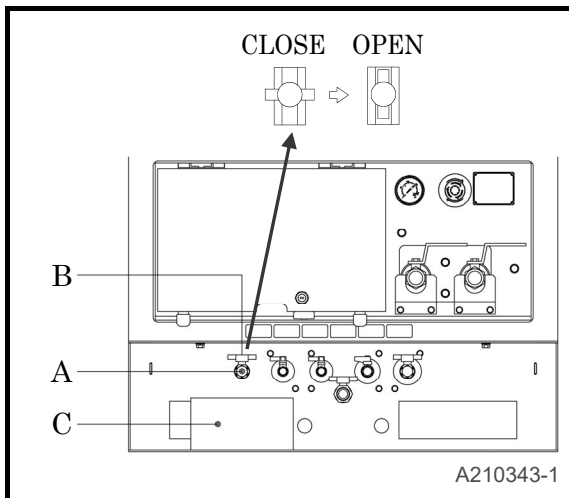

- First, remove the drain plug [A] on the outer side of the frame. Very slowly, open the drain valve [B] to drain the condensate.
- When all the condensate is drained away and the compressor oil starts to come out, close the drain valve [B] and mount the drain plug [A].
- Drain the condensate in container [C], and then dispose of condensate according to the designated regulations.
- When the fluid is difficult to distinguish by appearance, use a gloved hand and check its viscosity via touch to determine whether it is condensate or compressor oil.

WARNING

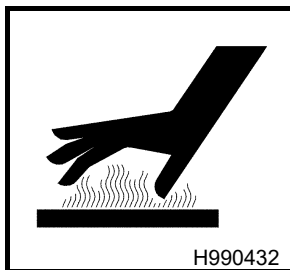

- After stopping the engine, confirm that the pressure gauge indicates 0psi(0bar) and there is no residual pressure in it, then open the drain valve gradually to drain the compressor oil.
- Should any residual pressure be left in the separator receiver tank, hot compressed air and hot compressor oil jetting out could cause burning or serious injury to persons nearby.
- A long-time operation with condensate accumulated could cause rust in the interior of compressor air-end, resulting in serious trouble.

3. Operation

3.3.5 Check fuel

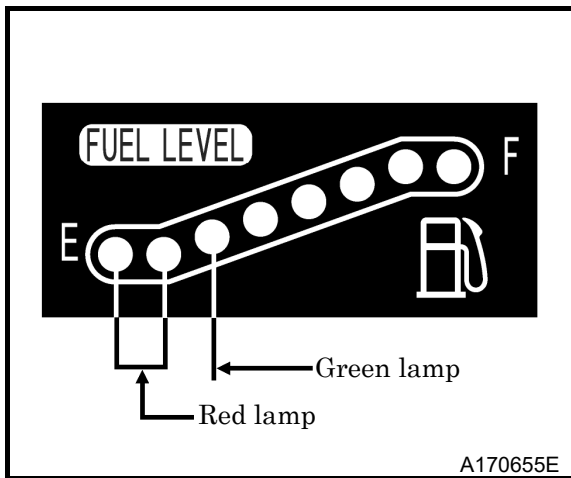

Before starting operation, make sure to check the level of residual fuel so that fuel shortage during operation can be avoided. Drain condensate accumulated at the bottom of fuel tank whenever necessary.

- Refueling should be done outdoors or in a well-ventilated place. Lamp is ON according to fuel level when control power switch of instrument panel is set to  position. Two red lamps are ON when fuel level is about 1/3 or less of maximum level. Only one red lamp blinks when fuel level becomes more less. Replenish fuel quickly when lamp is ON as red.

- Do not fill fuel up to the filler level.

When the fuel tank is filled up to the filler level, the expansion volume of the tank is too small and may lead to problems with fuel flow and containment. Furthermore, fuel may spill from the fuel tank due to vibration caused during movement or transportation of the unit.

CAUTION



- Do not, under any circumstance, bring lit cigarettes and/or matches near fuel.
- The fuel is extremely flammable and dangerous. Be aware of fire sources that can easily ignite the fuel.
- Refuel only after stopping the engine, and never leave open fuel cans near the machine. Do not spill. It is a fire hazard. When spills occur, wipe up thoroughly.

3.3.6 Drain fuel tank condensate

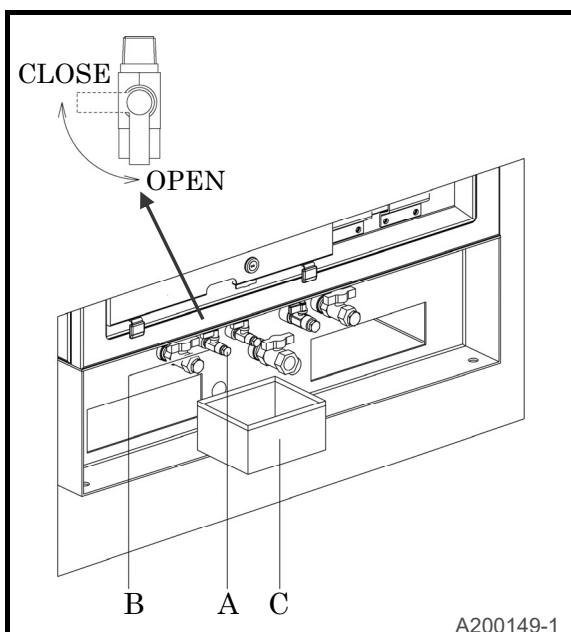

- After removing drain plug [A], open drain valve [B] gradually so as to discharge drain in fuel tank.
- When all the condensate is drained away and the fuel starts to come out, firmly shut the drain valve [B] and mount the drain plug [A].
- Drain the condensate in container [C], and then dispose of condensate according to the designated regulations.

3. Operation

3.3.7 Check Pre-filter for condensate

When red float [B] under element [A] in Pre-filter is raised up to upper level, drain water.

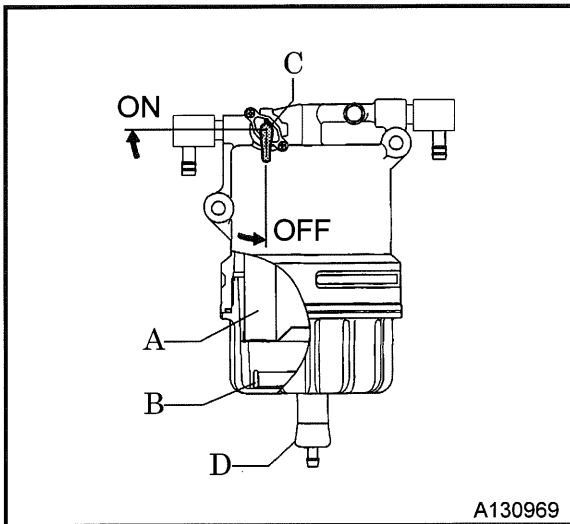

<Procedure>

1. Turn fuel selector valve [C] to "OFF" position.
 2. Loosen the drain valve [D] and drain out condensed water inside.
 3. After draining the condensate accumulated inside, make sure to firmly tighten the drain valve.
- Drain the condensate in container, and then dispose of condensate according to the designated regulations.

3.3.8 Check oil fence condensate

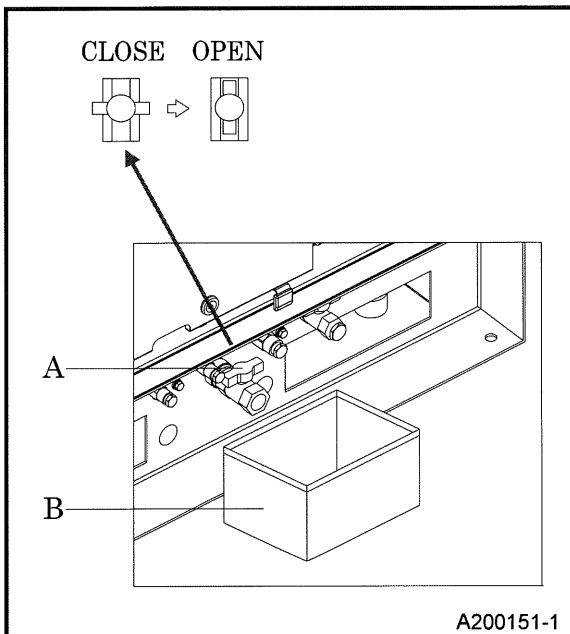

<Procedure>

1. Drain outlet of the oil fence is installed under the operation side. If condensate collected in the oil fence, open drain valve [A] and discharge it.
 2. After making sure that all condensate is completely drained out, close drain valve.
- Drain the condensate in container [B], and then dispose of condensate according to the designated regulations.

3. Operation

3.3.9 Check wiring of each part

Check if there are any loose wire connections or any scraped surfaces, damage, disconnections, misalignment, short circuits, etc., in the wiring.

3.3.10 Check piping of each part

Check each piping for any loose connection and also check each hose and pipe for any tear and leaks.

3.3.11 Periodical Inspection of Machine Insides

Periodically check the inside of the machine for dusts (rubbishes) and flammables.

CAUTION

- Be sure to wear protector such as helmet, protective glasses, earplug, safety shoes, gloves and dust protective mask for safety operation conforming with details of work.
- When any flammables such as chips of wood, dead leaves (dry leaves) and waste paper are left near heated exhaust muffler and heated exhaust pipe, all of them should be eliminated.
- Keep a fire extinguisher on hand near the machine in case of fire hazards.
- It is helpful to keep emergency contact numbers for urgent visit clinic, ambulance and firehouse.

3. Operation

3.3.12 Check belt tension

Follow the procedure below to adjust tension of fan belt and belt for alternator.
Adjust the tension by gradually loosening the fastening bolt [A] of the alternator.

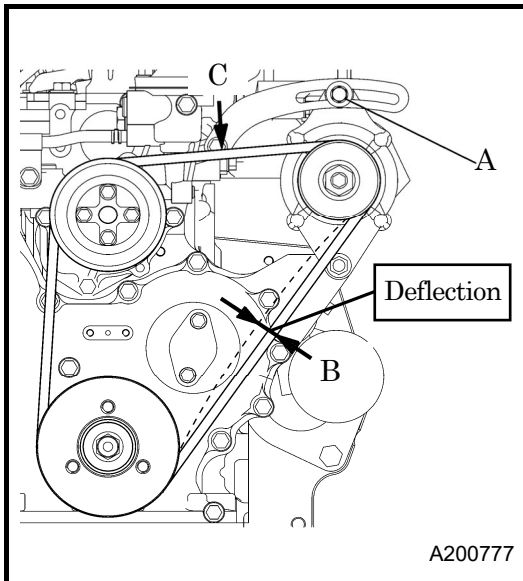

<Procedure>

1. Visually check if there are any cracks or tears in the belt.
2. Check that the deflection is as shown in the table below when you press the center [B] or [C] of the belt with your finger with a force of about 22lbf (98N). If not, loosen the adjustment bolt [A] of the alternator once and adjust again.

Inspection point	B	C
Deflection	0.39 to 0.55 in (10 to 14 mm)	0.28 to 0.39 in (7 to 10 mm)

3. Tighten the alternator mounting bolt [A] when the adjustment is completed.
 - Replace the belt if it has no adjustment range or if any cut, crack or other defect found.
 - Be careful not to leave any grease or LLC on a belt while changing it. If any such material is left, wipe it off completely.

WARNING

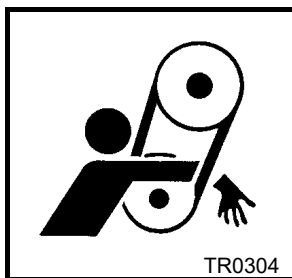

- Be sure to stop the engine whenever the tension of the belt is to be adjusted.
- Remove the negative (-) side cable from the battery.
- If the unit is not stopped, the operator's hand may be caught in the belt and cause serious injury.
- Be sure to stop the engine whenever check or maintenance work is carried out near the cooling fan.
- Otherwise, personnel could become caught by the fan and thus could be seriously injured.

IMPORTANT

- Too tight belt tension could damage shaft and shorten bearing life. Too loose belt tension may result in damaging belt earlier and machine components due to overheat.

3.3.13 Opening and closing doors

To open the door, pull the handle toward you to release the latch. Be sure to close the door tightly so that its latch is firmly caught.

WARNING



- Keep the door closed and locked while running the unit.
- When the door has to be opened, be careful not to touch portions that are rotating or very hot. Scalding burns or serious injury may result.

3. Operation

3.4 Operation



Make sure the door is closed securely.

3.4.1 Starting and Stopping Procedure

Follow the steps below to start up.

During the warm-up operation, examine the different parts of the equipment for any looseness, leakage of water, oil, fuel, and other irregularities. Also, set the service valve to “Fully close”. Make sure that the alarm lamp on the operation panel is off.

<Procedure>

1. Ascertain that the discharge air pressure gauge indicates 0 psi (0 bar).
2. Turn the control power switch [A] from  to , and the glow lamp [B] goes on.
3. When the glow lamp gone out, press and hold down the start button [D] for one second or more to start the engine.

The startup operation will stop automatically if it takes more than 30 seconds. If the machine fails to start after one attempt, wait longer than two minutes before attempting to start it again.

It could cause overheating to the starter motor and it could damage it. (See 3.4.2)

4. Once the engine has started up, leave it running to warm-up for 5 minutes. The discharge air pressure gauge [C] in this condition ranges from 44 to 118 psi (3.3 to 8.15 bar).

According to engine cooling water temperature, the times in the following table are required.

Engine coolant temperature	Required time for preheating	Required time for starting unloader operation
Higher than 50°F	1 sec	30 sec
Lower than 50°F	20 sec	Shorter time either 120 seconds or the time when engine coolant temperature becomes higher than 50°F.

5. After finishing warming up operation, open the service valve provided at the outlet of compressed air and start service job.

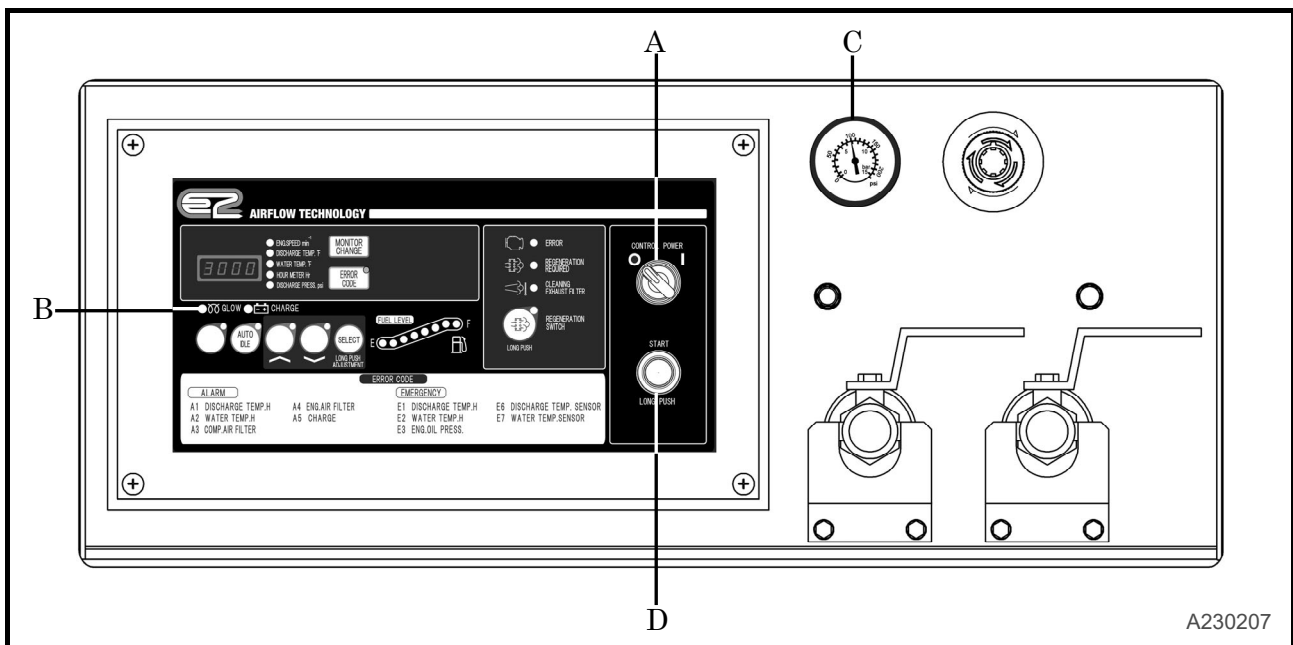

A230207

3. Operation

CAUTION

- Do not operate the machine with service valves and relief valve open unless air hoses and/or pipes are connected. High-pressurized air blows out and its air pressure could cause injury to the people nearby.
- When the machine has to be unavoidably temporarily operated with its port open, be sure to mount a silencer to reduce noise and wear protective materials such as earplugs to prevent damage to hearing.

IMPORTANT

- Be sure to let unit warm-up after starting for smooth operation of the engine and the compressor.
- Do not carry out on-load operations immediately after turning the machine on, as this could result in a shorter machine life.

3.4.2 Operating procedures when engine fails to start up on first attempt

If the engine did not start even when you performed Steps 1 through 3 of Section 3.4.1, return the control power switch [A] to the  position and wait about more than two minutes. Then, perform the engine-starting operation again. If the repeated procedure does not allow the engine to run, the following causes are suspected. Therefore, check the following:

- No fuel
- Lack of air bleeding in fuel line (**See 3.4.6**)
- Fuel filter clogging.
- Battery discharge (Low cranking speed)

3.4.3 Operation in cold weather

- Use engine oil of a viscosity that meets the ambient temperature according to 3.2.1.
- Use LLC (antifreeze). Use correct amount to provide freeze protection, according to the ambient temperature according to 3.2.3.
- Battery should always be kept fully charged.

CAUTION

- When operating the unit in a low temperature, change engine oil, compressor oil, LLC (antifreeze) and diesel fuel according to the ambient temperature.

3. Operation

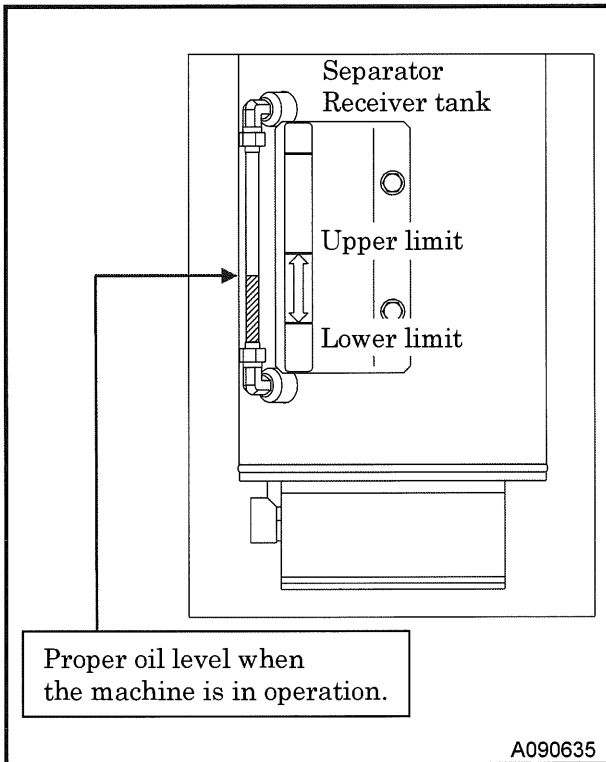

- When the machine is in operation under load, check to see that the compressor's oil level falls within the range between the lower limit and upper limit of the level gauge if the level is found to be insufficient, replenish the oil.
- ※ Keep the operation log to record constant inspection of each component, so that trouble of the machine can be easily discovered and preventive measures can be taken.

CAUTION



- Do not open the valves below listed when operating.
- Separator receiver tank condensate drain valve (with plug)
- Radiator condensate drain valve (with plug)
- Engine oil condensate drain valve (with plug)
- Oil cooler condensate drain valve (with plug)
- Fuel tank condensate drain valve (with plug)
- Oil fence condensate drain valve

IMPORTANT

- Minimum discharge air pressure is 58psi (4bar) during operation.
- Continuing equipment operation at a lower pressure than the above pressure may cause overheating, since it affects the separation of lubricating oil inside the oil separator and reduces the oil flow to the compressor air-end, resulting in temperature rise.

3. Operation

3.4.5 Procedure to stop the machine

<Procedure>

1. Close the service valve completely and operate the machine about 5 minutes, until it cools down.
2. Turn the control power switch to the  position to stop the engine.
3. Remove the key from the compressor every time when you stop the engine. Keep the key and be careful not to lose it.

3.4.6 Air bleeding in fuel line

Should the machine stop due to fuel shortage, perform air bleeding according to the following steps.

<Procedure>

1. Refuel.
2. Turn the control power switch to the  position, electromagnet pump starts to automatically bleed air in fuel line.
3. Air bleeding is completed about 1 minute.

3. Operation

3.5 Capacity Control Device

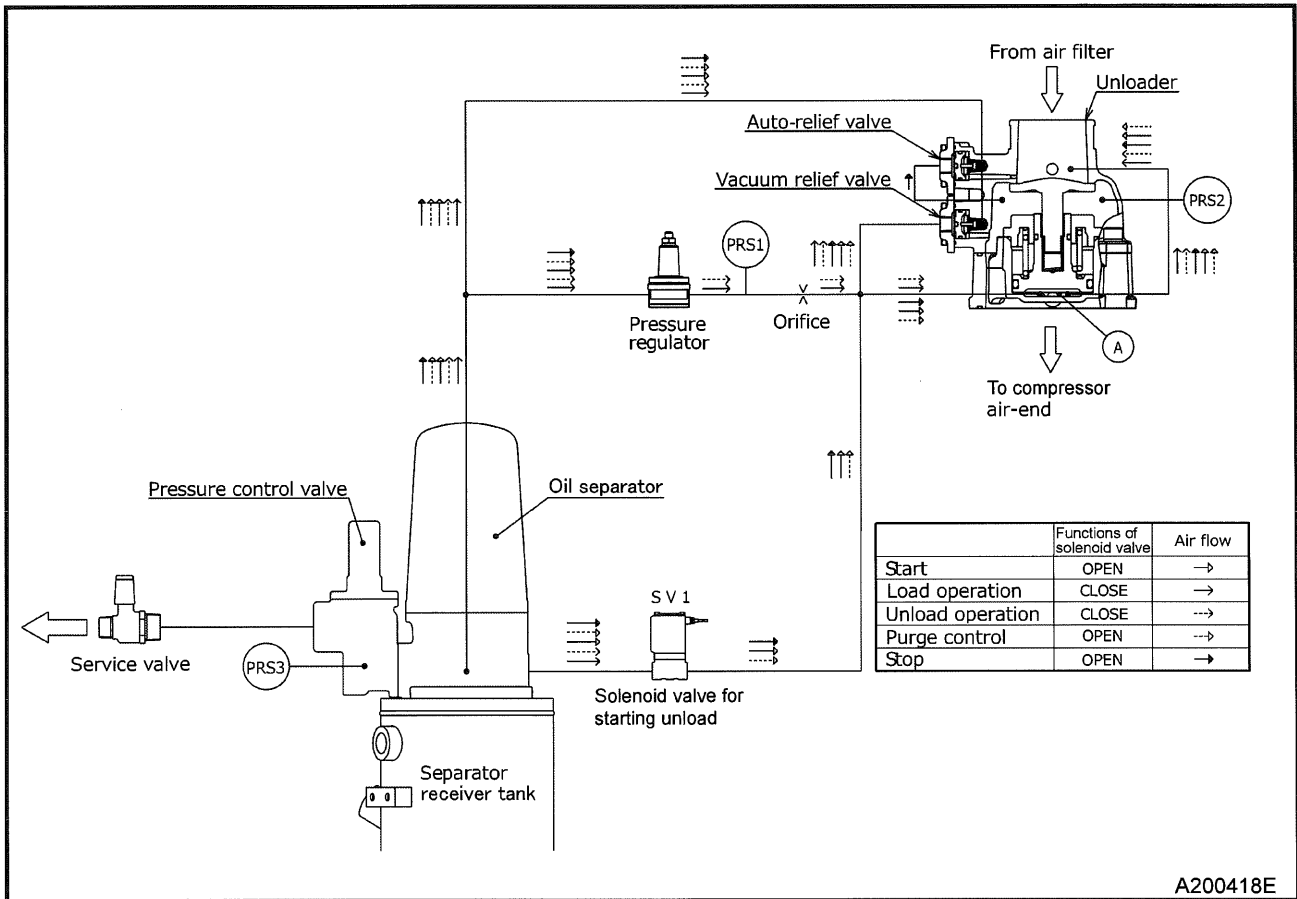

Step	Response
Start	Compressed air flows into unloader chamber (A) because solenoid valve for purge control SV1 is opened at start-up. The pressure in chamber (A) rises soon to close unloader valve (A) fully and accordingly it can reduce the load at start-up.
Load operation	After starting, SV1 is closed after automatic unloaded operation, and the air volume which is sent to chamber (A) increases and decreases according to the rise and drop of the discharge air pressure and consequently the opening width of the unloader valve is changed. Further, engine revolution (RPM) is changed by the pressure which PRS1 detects, and it steplessly controls the air volume in the range from 0 to 100%.
Suction port closing unload operation	When compressed air pressure exceeds the rated pressure with reduction of air consumption, PRS1 detects the pressure and it reduces engine speed (rpm) in proportion to the pressure rise, and it closes unloader valve at the same time. When compressor air-end becomes vacuum during unload operation, vacuum noise is caused. To prevent this noise, it opens vacuum relief valve by detection of secondary pressure of pressure regulator. Thus high vacuum condition of compressor air-end is prevented.
Purge control unload operation	When the certain set time (it can be changed.) has passed at lower pressure than the set negative pressure, detecting the negative pressure inside the compressor air end with a pressure sensor PRS2, solenoid valve SV1 opens and it closes unloader valve. At the same time, it functions to relieve the compressed air from separator receiver tank to the atmosphere and thus it lowers the pressure. Thus the compressor power is saved. When air consumption increases, and the pressure used for load drops below the set pressure, pressure sensor PRS3 detects it and it disengages the purge control (SV1 closes) to start full load operation.
Stop	When stopping operation, it opens Auto relief valve to relieve the compressed air in separator receiver tank to atmosphere, detecting the pressure inside compressor air-end.

3. Operation

3.5.1 AUTO IDLE control (Purge control)

This model is equipped with auto idle control operation mode. This operation mode is recommendable for such use: not so much air consumption is required and it is used continuously and also power consumption under unloaded operation is required to be saved. Use this mode, depending upon the need and demand. For the selection of this mode, switch on “AUTO IDLE” on the operation panel. Select this operation mode freely, according to required air consumption.

<Procedure>

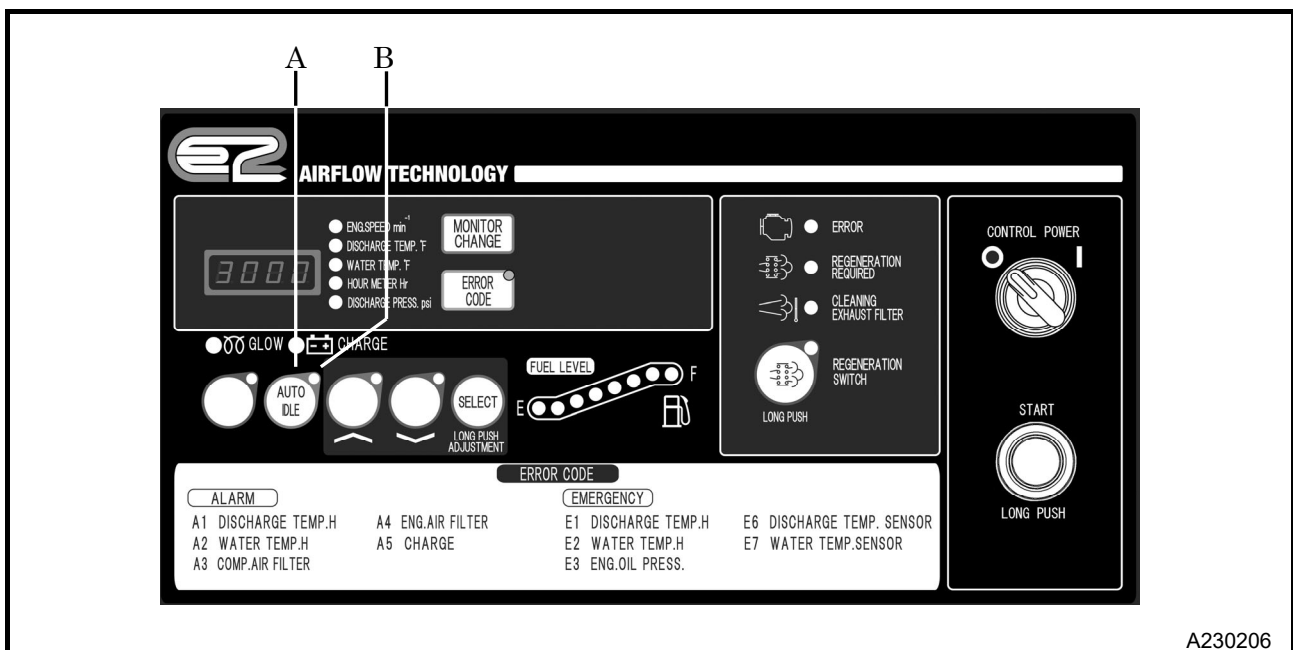

1. During operation, long push on the switch [A] “AUTO IDLE”.
2. Then the indicator lamp auto idle [B] goes on.
3. In order to stop this operation mode, push again auto idle switch [A] and then the lamp goes out to disengage this purge control.



A230206

3. Operation

[Function of auto idle control (Purge control)]

Function	Conditions of auto idle lamp
<p>1. First engine speed drops to the minimum speed by pressure regulator, owing to reduction of air consumption. Later the air consumption is reduced further, the unloader valve gradually closes and intake negative pressure increases. In this stage, the pressure sensor detects the intake negative pressure. Then when the intake negative pressure becomes higher than the set pressure, the "AUTO IDLE" lamp flickers at short intervals.</p>	 Lamp flickers at short intervals.
<p>2. When this condition continues for a certain time, the solenoid valve functions to start purge mode operation. Consequently, the pressure inside separator receiver tank drops and reduces the power of compressor air end. In this stage, the lamp "AUTO IDLE" flickers at longer intervals.</p>	 Lamp flickers at longer intervals.
<p>3. Next, when the pressure for load down to the purge releasing pressure owing to the increase of air consumption, the solenoid valve operation gets "OFF" and it is transferred to normal operation. In this stage, the lamp "AUTO IDLE" goes on.</p>	 Lamp goes on.

3. Operation

3.6 DPF regeneration

WARNING

- During DPF regeneration operation, exhaust gas of high temperature is discharged. Check and confirm that there is no person nor flammables near by. It could cause scalding to person and fire.
- During regeneration operation, take care of carbon monoxide poisoning in closed space.

- When regeneration control is begun and finished, noise of engine air intake throttle and EGR opening width adjustment is sometimes caused. But this phenomena is not abnormal.
- The smell of the exhaust gas caused during regeneration operation is different from that of diesel fuel used in the past.

3.6.1 Passive Regeneration

- Soot collected in the DPF is burnt automatically because of high temperature during normal operation under heavy load application.

3.6.2 Active Regeneration

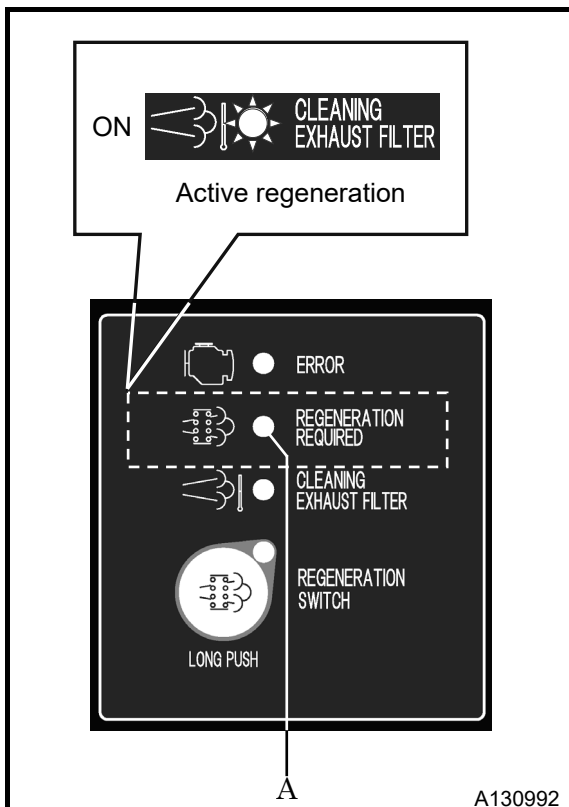

- When the accumulated amount of soot collected by the DPF reaches the prespecified value, the machine will move to automatic regeneration mode.
- During automatic regeneration mode operation, it is possible to continue servicing job.

<Active regeneration mode>

1. Cleaning exhaust filter lamp [A] is ON.
2. This regeneration process will last for about 30 minutes. (※1)
3. The lamp will be OFF when the regeneration is completed.

※1 Time required for regeneration depends on load factor and ambient temperature.

CAUTION

- Do not stop engine during automatic regeneration operation, except for unavoidable conditions.

3. Operation

3.6.3 Manual Regeneration

- Especially when ambient temperature is very low and in almost no-load operation, incomplete soot combustion occurs. If operated continuously in the same conditions, regeneration required lamp goes on soon. In this case, take necessary procedure for enforced regeneration operation according to the following steps.

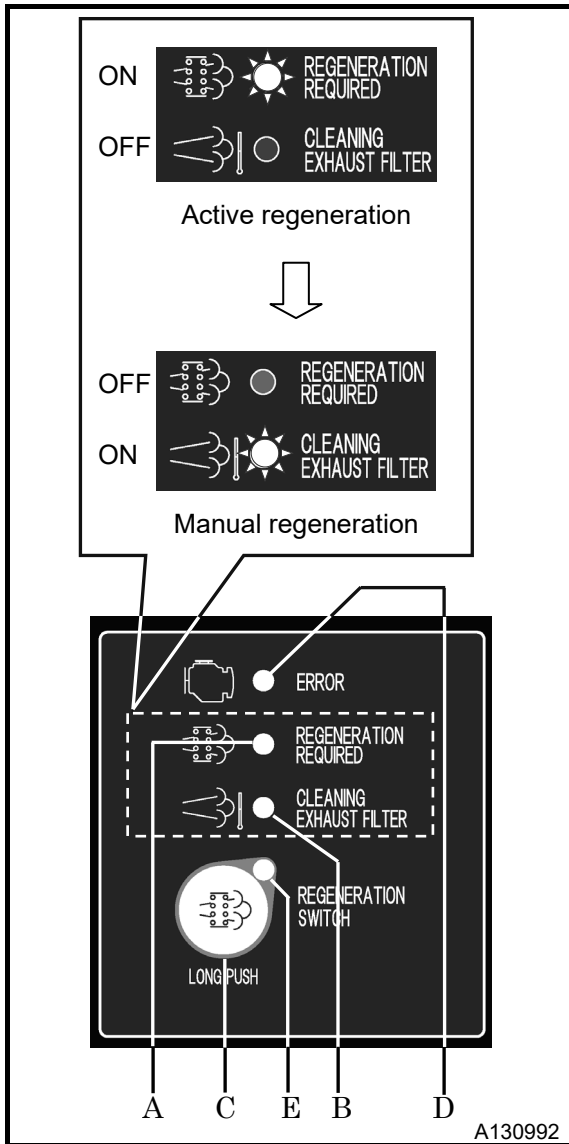

<Manual Regeneration Procedure>

- REGENERATION REQUIRED lamp [A] and ERROR lamp [D] go on. At the same time, REGENERATION SWITCH lamp [E] flashes. And also engine speed automatically changes to $1,350\text{min}^{-1}$.
- Fully close the service valves
- Keep pressing REGENERATION SWITCH [C] longer than 3 seconds.
- REGENERATION REQUIRED lamp lights off and CLEANING EXHAUST FILTER lamp [B] goes on, Then REGENERATION SWITCH lamp [E] changes to lighting on instead of flashing and at the same time it automatically starts purge operation.
- Engine speed gradually increases up to approximately $2,200\text{min}^{-1}$.
- Under this state, manual regeneration operation is performed about 30 minutes. **(※2)**
- All lamps go off and manual regeneration operation comes to end, and it returns to normal engine speed and normal operation starts.

※2 Time of regeneration varies upon the ambient

- When continuing operation about ten hours without conducting manual regeneration even while REGENERATION REQUIRED lamp [A] is lighting, it will be impossible to conduct manual regeneration and it leads to low idling operation only. In this case, it becomes necessary to clean DPF (Diesel particulate filter). Please contact our nearest dealer.

IMPORTANT

- When DPF regeneration lamp goes on, take immediate specified action to conduct manual regeneration.
If it is continuously operated without manual regeneration, excessive soot will accumulate and it could damage DPF due to abnormal burning, and it could cause a fire.

CAUTION

- Do not stop engine during enforced regeneration operation, except for unavoidable conditions.

3. Operation

3.7 Emergency Stop

3.7.1 Emergency stopping procedures

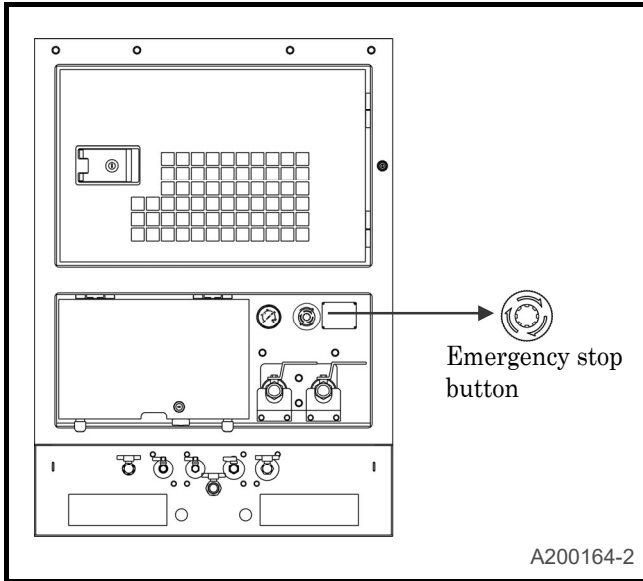

- If any emergency occurs with the machine itself or in the immediate surroundings while the machine is in operation and requires an immediate stop, press the emergency stop button on the right-hand side of the operation panel. When pressing the emergency stop button, the machine will be stop immediately.
- When shutting down with the emergency stop button, the control power is “ON”. After shutting down, make sure to turn the control power switch to the  position, and then lock the cover on the front of the instrument panel, remove the key. Do not look inside the machine and take inspection right after shutting down.

3.7.2 Resetting the emergency stop button

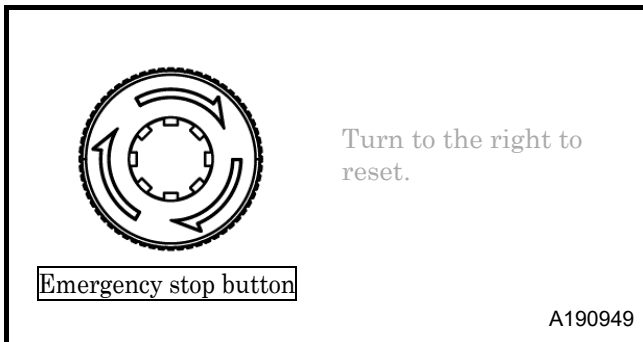



- After emergency stopping, be sure to carry out an investigation of the problem which caused you to use the emergency stop and take appropriate countermeasures. Release emergency stop button after making sure the safety was confirmed. To reset the button, turn the button head in the direction of the arrow.
- ※ If it is not reset, the machine cannot restart operation.

4. Failure cause and measures

4.1 Indicator lamp and Warning / Emergency display

[Indicator lamp] Turn the control power switch  position. Then the lamp goes on.

Item	Contents	Measures	Monitor
GLOW	Control power switch  position and the lamp goes on and after preheating is finished, the lamp will be off.	—	
CHARGE	Lamp goes on when alternator is not charging.	Check wiring. Check alternator.	

4.1.1 Warning Display

This displays such trouble of less importance when it occurs during operation, but the unit continues operating.

When any abnormality happens, a trouble code lamp flickers. In this time when trouble code switch is pressed, a failure code will be digital monitor.

Item	Failure code	Contents	Measures
DISCHARGE TEMP. H	A-1	Lamp displays when the air temperature at the outlet of the air-end reaches 239°F (115°C).	See 4.2 “Troubleshooting”
WATER TEMP.H	A-2	Lamp displays when coolant temperature reaches 221°F(105°C).	
COMP.AIR FILTER	A-3	When the air filter gets clogged and suction resistance increases, lamp comes on. [Actuating resistance: 6.2kPa or more]	Clean or replace
ENG. AIR FILTER	A-4		
CHARGE	A-5	Belt loosened and/or cut Faulty generation of alternator	See 4.2 “Troubleshooting”

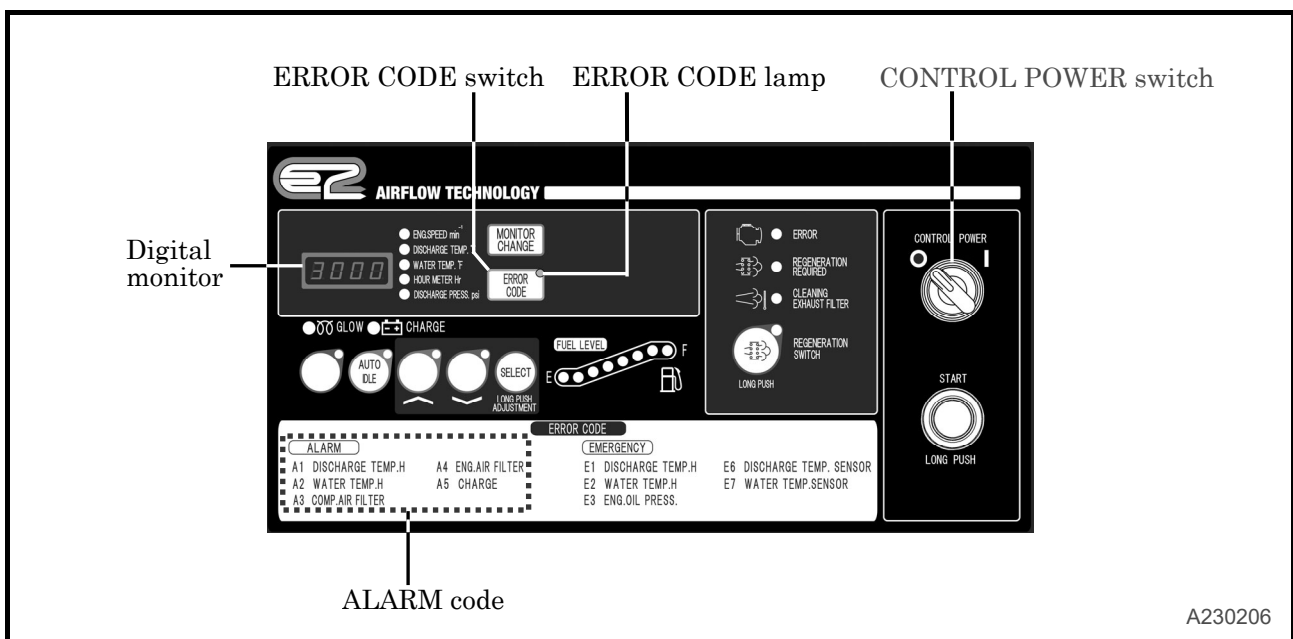

4. Failure cause and measures

4.1.2 Emergency Display

When any trouble takes place during operation, this displays and it stops as an emergency stop. When any abnormality happens, a trouble code lamp goes on. In this time when trouble code switch is pressed, a failure code will be digital monitor.

Item	Failure code	Contents	Measures
DISCHARGE TEMP.E	E-1	Lamp displays when the air temperature at the outlet of the air-end reaches 248°F (120°C).	See 4.2 “Troubleshooting”
WATER TEMP.E	E-2	Lamp displays when coolant temperature reaches 230°F(110°C).	
ENG. OIL PRESS.	E-3	Lamp goes on when engine oil pressure drops. [The function pressure: 7.3psi(0.5bar)]	
DISCHARGE AIR TEMP. SENSOR DISCONNECTION	E-6	Discharge air temperature sensor of the discharge air outlet disconnected.	
COOLANT TEMP. SENSOR DISCONNECTION	E-7	It is displayed when engine coolant temperature sensor is disconnected.	

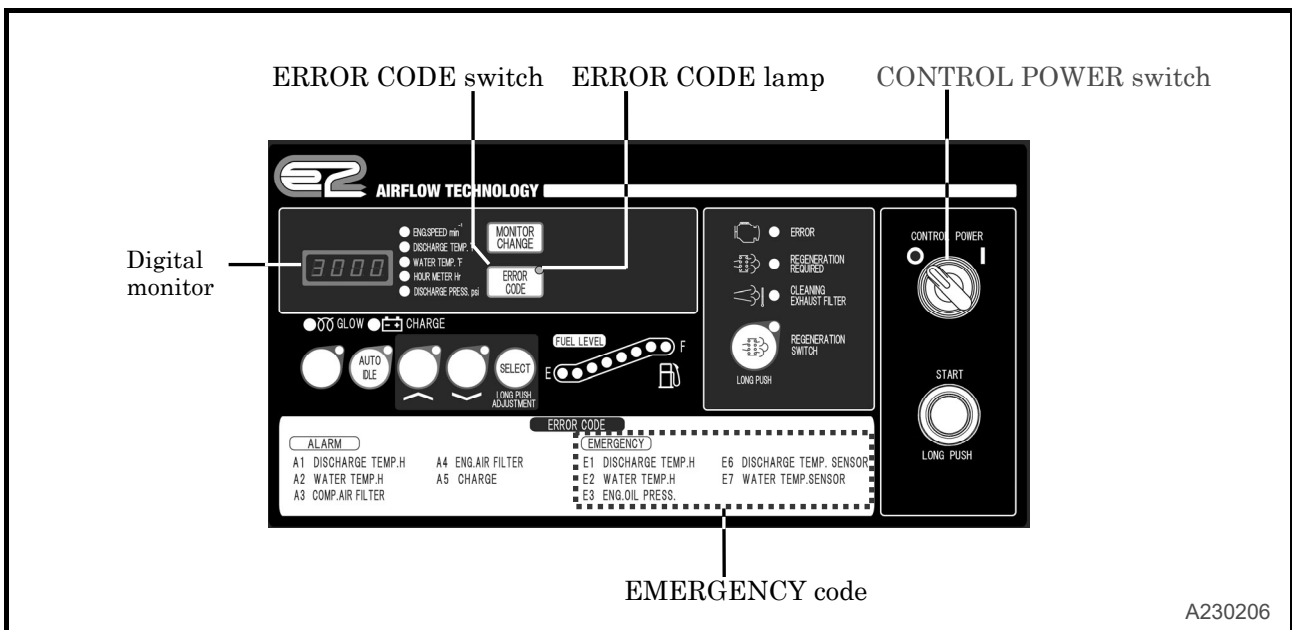

4. Failure cause and measures

4.2 Troubleshooting

Should any trouble occur during operation, do not leave it. Investigate the cause and take appropriate measures. Read the manual carefully and fully understand what to do in case of trouble.

- The better you understand the construction and function of the unit, the faster you can find the problem and solution.
- This chapter describes the symptom, cause and countermeasures of important troubles in detail.

4.2.1 Compressor version

If a problem occurs with the compressor, take appropriate inspection and measures referring to the table below.

Symptom	Cause	Countermeasures
Discharge air pressure does not reach 100psi(6.9bar).	(1) Pressure regulator insufficient adjustment. (2) Trouble of solenoid valve for starting unloader.	Re-adjust (fasten) Change
Engine does not reach its maximum speed.	(1) Failure of the engine controller (2) Unloader orifice clogging. (3) Engine trouble. (4) Fuel filter clogging. (5) Water is accumulated in fuel pre-filter. (6) Air filter element clogging.	Call your nearest dealer Disassemble/Clean Call your nearest dealer Disassemble/Change Drain water Clean or change of element
Revolution drops before discharge air pressure reaches 100psi(6.9bar).	(1) Pressure regulator insufficient adjustment. (2) Trouble of pressure regulator. (3) Unloader orifice clogging.	Re-adjust (fasten) Change Disassemble/Check
Engine does not reach minimum revolution at unload.	(1) Failure of the engine controller (2) Failure of the accelerator controller.	Call your nearest dealer Call your nearest dealer
Safety valve relieves at unload.	(1) Pressure regulator insufficient adjustment. (2) Unloader valve damaged·Faulty seat (3) Faulty safety valve. (4) Engine speed sensor trouble.	Re-adjust (loosen) Call your nearest dealer Change Change
Oil mixes in air. (poor oil separation)	(1) Scavenging orifice strainer clogging. (2) Excessive oil in separator receiver tank. (3) Low discharge pressure. (4) Oil separator element deteriorated.	Disassemble/Clean Drain to its proper level Unloader Disassemble/Check Check /Change
Insufficient free air delivery.	(1) Air filter element clogging. (2) Unloader valve cannot fully open. (3) Engine does not reach rated speed.	Clean or change of element Call your nearest dealer Call your nearest dealer
Discharge air temperature alarm (A-1) Discharge air temperature error (E-1) and engine stoppage	(1) Shortage of compressor oil. (2) Belt slippage. (3) Oil cooler clogging. (4) Oil filter element clogging. (5) Loose wiring connectors and disconnection. (6) Faulty discharged air temp. switch. (7) Discharge air temp. sensor is disconnected.	Replenish oil Re-adjust tension Clean Change Check/retighten Disassemble/Check Repair and replace
Coolant temperature alarm (A-2) Coolant temperature error (E-2) and engine stoppage	(1) Coolant shortage. (2) Belt slippage. (3) Clogged radiator. (4) Faulty thermostat. (5) Loose wiring connectors and disconnection. (6) Faulty coolant temp. switch. (7) Coolant temp. sensor is disconnected.	Replenish coolant Re-adjust tension Clean Change Check/retighten Change Repair and replace

4. Failure cause and measures

Symptom	Cause	Countermeasures
Engine oil pressure error (E-3) and engine stoppage.	(1) Engine oil shortage. (2) Clogged engine oil filter. (3) Loosened or disconnected wiring or connectors. (4) Faulty oil pressure switch.	Replenish engine oil Change Check/retighten Change
Charge error (A-5)	(1) Belt damage. (2) Belt slippage. (3) Alternator wiring/connector loosen/come off. (4) Alternator trouble	Change Re-adjust tension Check/Fasten Call your nearest dealer
Discharge air temperature sensor disconnection (E-6) or coolant temperature sensor disconnection (E-7) is displayed, and the engine is stopped.	(1) Each sensor's wiring/connector loosen/come off. (2) Each sensor has error. (3) Each sensor disconnects.	Check/retighten Disassemble/Check Repair and replace
Engine monitor alarm lamp glows.	(1) Engine in trouble	※1
Engine trouble lamp and DPF REGENERATION REQUIRED lamp light on.	(1) DPF gets clogged.	Enforced regeneration operation should be performed in the following cases. (Refer to 3.6 clause.)

※1 After having found the cause with a service tool, it is necessary to take measures. Therefore, please contact your nearest distributor.

- Contact your nearest dealer if you find it difficult to repair by yourself.
- Refer the section “4.2.2 Engine body version” when facing engine trouble.

4. Failure cause and measures

4.2.2 Engine body version

In case engine trouble occurs, refer below table and do appropriate check and maintenance.

Symptom	Cause	Countermeasures
Engine does not start		
Starter motor operates but engine does not start	(1) No diesel fuel	Refuel and prime fuel system
	(2) Air in fuel lines	Prime fuel system
	(3) Improper diesel fuel	Replace with recommended diesel fuel
	(4) Clogged fuel filter	Replace fuel filter
	(5) Poor fuel injection	Call your nearest dealer
	(6) Compressed air leakage from intake/exhaust valves	
	(7) Faulty engine stop solenoid	
Starter motor does not operate or rotates too slowly (engine can be turned manually)	(1) Battery needs charging	Check electrolyte, recharge
	(2) Faulty cable connection at battery terminals	Clean terminals, retighten
	(3) Faulty starter motor	Call your nearest dealer
Engine cannot be manually turned	(1) Inner parts seized or damaged	
White or black exhaust smoke		
Black exhaust smoke	(1) Engine overloaded	Reduce load
	(2) Clogged air cleaner	Clean element or replace
	(3) Improper diesel fuel	Replace with recommended diesel fuel
	(4) Faulty spraying of fuel injection	Call your nearest dealer
	(5) Excessive intake/exhaust valve clearance	
	(6) Faulty EGR valve	
White exhaust smoke	(1) Improper diesel fuel	Replace with recommended diesel fuel
	(2) Faulty spray pattern of fuel injection	Call your nearest dealer
	(3) Fuel injection timing delay	
	(4) Engine burning oil	

4. Failure cause and measures

4.3 Adjustment of Various data

The following set values can be altered and adjusted.

No.	Item	Indication	Unit	Primary set value	Range of set values
1	Purge releasing pressure		PSI	86	70~100
2	Waiting time for transfer to purge mode operation		Second	10	5~60
3	Load factor for transfer to purge mode operation		%	15	5~30
4	The high-speed side correction (Full load rotational speed)		min ⁻¹	100	0~200
5	The low-speed side correction (Unload rotational speed)		min ⁻¹	100	0~200

<Procedures of adjustment>

When SELECT switch is pressed longer (than 5 second), first P. (Purge releasing pressure) is displayed. Each time SELECT switch is pressed, each indication will be selected. Then each time it is pressed one time, T. (Waiting time for transfer to purge mode operation) is switched to b. (Load factor for transfer to purge mode operation) to H.(Full load rotational speed) to L.(Unload rotational speed), according to the set orders.

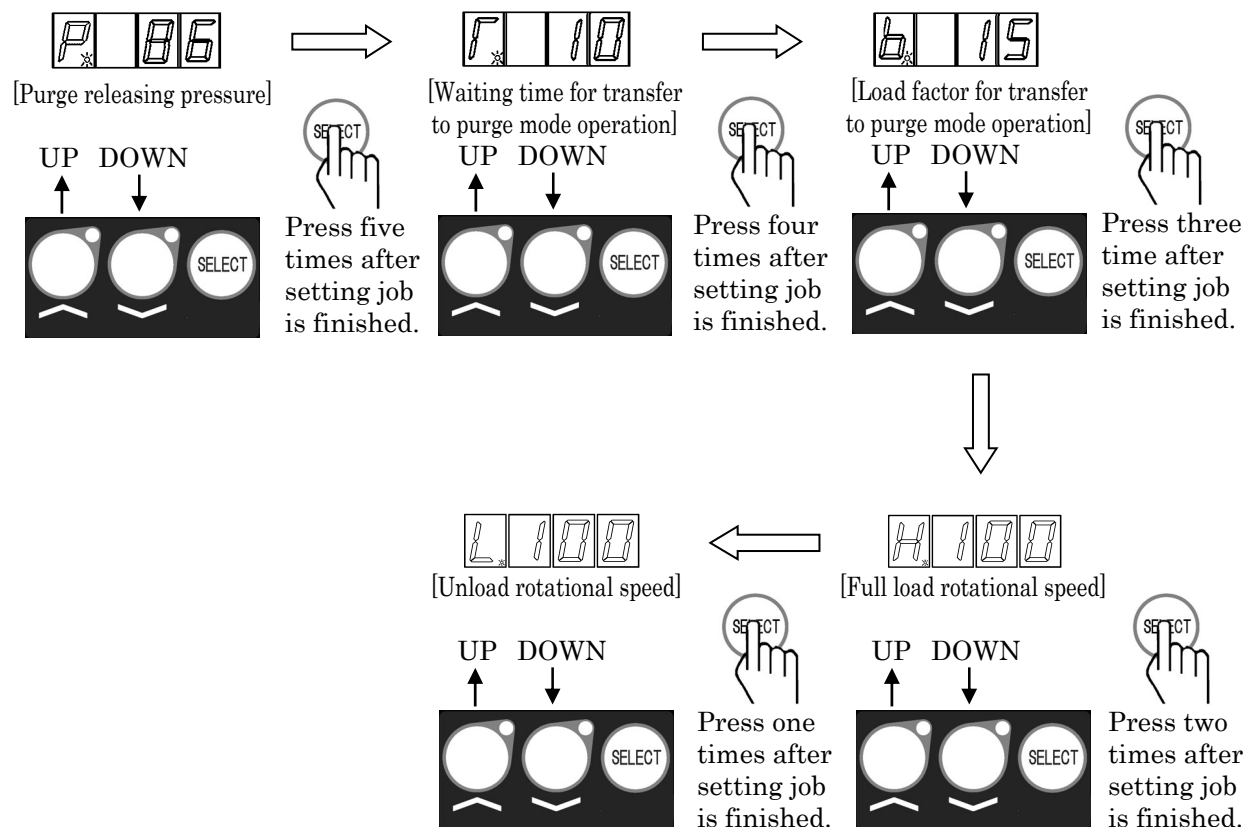

5. Periodic Inspection/Maintenance

5.1 Important Items at Periodic Inspection and Maintenance or after Maintenance

This manual shows the inspection and maintenance intervals under normal operating conditions, not the warranty period. When using under severe environmental conditions or operating conditions, shorten the maintenance interval.

- Please wear protection implements, such as a helmet, protection glasses, earplugs, safety shoes, a glove, and a protection-against-dust mask, according to the contents of work for safety.
- Take care not to touch hot portions of the machine while inspecting during operation. Such parts as engine, exhaust manifold, exhaust pipe, muffler, radiator, oil cooler, air-end, pipe, separator receiver tank, and discharging pipe are especially hot, so never touch these parts, it will cause burning.

WARNING

Hang an “Under Maintenance” tag

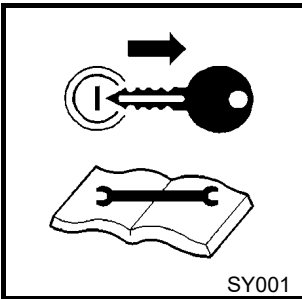

- Before starting inspection, make sure to turn the CONTROL POWER switch to the  position, and then lock the door on the front of the instrument panel, remove the key, and hang up a “Now Checking and under Maintenance” tag where it can be easily seen. The checker must keep the key during checking and maintenance.
- Remove the negative (-) side cable from the battery. If the above procedure is neglected, and another person starts operating the machine during check or maintenance, it could cause serious injury.

CAUTION

Prevention of oil separator from catching fire

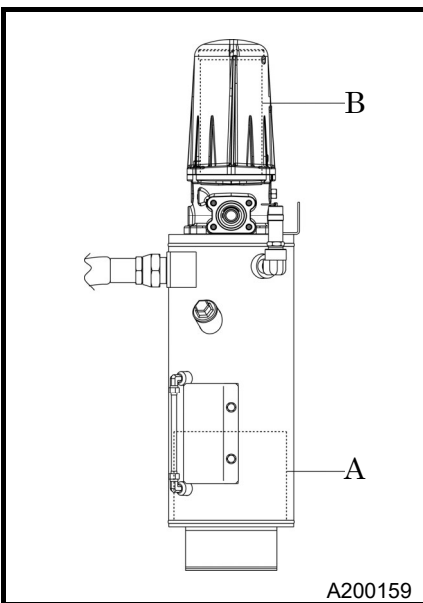

- Be sure to perform following periodic inspection and maintenance:
 - A. Check and change compressor oil quantity
 - B. Change oil separator element

5. Periodic Inspection/Maintenance

IMPORTANT**Uninstructed/unspecified work prohibited**

- Be sure to use recommended fuel, oil, grease, and LLC (antifreeze).
- Do not disassemble or adjust engine, compressor air-end or part(s) for which inspection or maintenance is not referred to in this manual.
- Use genuine parts for replacement.
- Any breakdown, caused by using unapproved parts or by wrong handling, will be out of the scope of "WARRANTY".
- Keep the electrical components away from water or steam.
- Place a container or a pan underneath the oil port to catch waste liquid so that such liquid does not spill on the floor or inside the machine.
- Waste from machines contains harmful material. Do not dispose of such harmful fluids to the ground, rivers, lakes or ponds, and sea. It contaminates the environment.
- Be sure to follow the designated regulations when disposing of oil, fuel, LLC (antifreeze), filters, battery and other harmful things.

5. Periodic Inspection/Maintenance

5.2 Periodic Inspection List

(Unit: Hour)

Maintenance Items		Daily	250	300 (First time)	500	1,000	2,000	3,000	8,000	Ref. Page
Compressor	Check compressor oil level	○								3-6
	Drain separator receiver tank	○								3-7
	Check for looseness in pipe connecting part, and wear and tear of pipe	○								3-10
	Check oil, water, fuel and air leak	○								3-14
	Check functions of all instruments and devices	○								3-14
	Check and clean clogging of air filter element		○							5-9
	Change compressor oil			○	○					5-10
	Change compressor oil filter element			○		○				5-11
	Change air filter element				○					5-11
	Clean strainer in the scavenging orifice				○					5-12
	Clean exterior of the oil cooler					○				5-13
	Change oil separator element						☆●			5-14
	Change nylon tubes						☆●			5-16
	Change rubber hoses							★●		5-16
	Change solenoid valve for starting unload							●		5-16
	Change O-ring of unloader							★●		5-16
	Change pressure regulator							★●		5-17
	Check that the pressure control valve is working and replace any consumables							●		5-17
	Inspect and replace any consumables for the auto relief and vacuum relief valves							★●		5-18
	Change oil seal/bearing								●	5-18

Items marked with a ○ are to be performed by the customer. For the following items or clauses marked with a ●, contact your nearest dealer because they require expert technical knowledge to perform.

- ※ The items or parts marked ☆ should be replaced every 2 years even if they are not in disorder within their periodical maintenance interval because their materials will change or become degraded as time passes. Also for the same reason, the parts marked ★ should be replaced every 3 years.
- ※ The indicated replacement periods are rough estimates. Depending on the usage conditions or environment, inspection/maintenance should be conducted earlier.
- ※ The above intervals of inspection and maintenance are respectively based on 1,000 hours of use per year.

5. Periodic Inspection/Maintenance

(Unit: Hour)

Maintenance Items		Daily	50 (First time)	250	500	1,000	2,000	3,000	Ref. Page
Engine related	Check engine oil level	○							3-4
	Check coolant level	○							3-5
	Check fuel	○							3-8
	Drain fuel tank condensate	○							3-8
	Check Pre-filter for condensate	○							3-9
	Check looseness in pipe connectors, terminals and tear in wiring	○							3-10
	Check belt tension	○							3-11
	Change engine oil		○	○					5-6
	Change engine oil filter element		○	○					5-7
	Check battery electrolyte			○					5-7
	Check and clean clogging of air filter element			○					5-9
	Check specific gravity of battery electrolyte				○				5-7
	Change air filter element				○				5-11
	Change of fuel filter element				○				5-12
	Change of element inside fuel pre-filter				○				5-13
	Clean exterior of the radiator					○			5-13
	Clean interior of radiator					●			5-14
	Change coolant (LLC)						☆○		5-15
	Clean fuel tank interior						●		5-14
	Change fuel hose						☆●		5-16
Change radiator hoses							★●	5-17	
Cleaning of the EGR cooler					●			※1	
Clean DPF							●	※2	
Check and cleaning of the EGR valve / reed valve						● (Every 1,500 hours)		※2	
Operational check of the exhaust throttle valve							●	※2	
Change and check of the injector							●	※2	
Others	Check oil fence condensate	○							3-9
	Clean the oil fence and check for rust					●			5-14

Items marked with a ○ are to be performed by the customer. For the following items or clauses marked with a ●, contact your nearest dealer because they require expert technical knowledge to perform.

※1: Perform cleaning every 1,500 hours of operation.

※2: For inspection or replacement, contact your nearest dealer or engine manufacturer.

※ The items or parts marked ☆ should be replaced every 2 years even if they are not in disorder within their periodical maintenance interval because their materials will change or become degraded as time passes. Also for the same reason, the parts marked ★ should be replaced every 3 years.

※ The indicated replacement periods are rough estimates. Depending on the usage conditions or environment, inspection/maintenance should be conducted earlier.

※ The above intervals of inspection and maintenance are respectively based on 1,000 hours of use per year.

5. Periodic Inspection/Maintenance

(Unit: Hour)

Maintenance Items		1,000	1,500	3,000	6,000	Remarks
Engine body	Check and adjust intake/exhaust valve clearance	●				
	Inspect the crankcase breather system		●			
	Inspect ECU and related sensors and actuators			●		
	Inspect clean and test EGR valve			●		
	Inspect DPF DOC			●		
	Inspect and test intake throttle valve			●		
	Check and clean injector			●		
	Check and clean of DPF soot filter				●	

5.3 Periodic Replacement of Parts

Part numbers change upon modification. For replacement of parts, contact your nearest dealer to verify the part number is correct or applicable.

Part Name		Part Number	Quantity
Engine oil filter element		41290 01200 YANMAR 129150-35153	1
Air filter element	Compressor air-end	32143 11800	2
	for engine side		
Compressor oil filter element		37438 08900	1
Compressor oil filler port O-ring [F]		03402 25030	1
Fuel filter element		43543 02100 YANMAR 129A00-55800	1
Fuel pre-filter element	Element	YANMAR 129A00-55730	1
	O-ring (For element)	YANMAR 129A00-55740	1
	Drain plug (With O-ring)	YANMAR 129242-55740	1
Solenoid valve for starting unload		46811 30000	1
Oil separator	Element	34224 03000	1
	O-ring	03402 15145	1
Pressure control valve	O-ring [A]	03402 15075	1
	O-ring [B]	03402 25032	1
	Spring [C]	22144 07700	1
	Piston [D]	35303 03300	1
Pressure regulator		36400 19000	1
Belt		YANMAR 129612-42350	1

5. Periodic Inspection/Maintenance

5.4 Maintenance Items

5.4.1 Change engine oil (Replace the engine oil filter element at the same time.)

At 50 hours for the first change and at every 250 hours thereafter

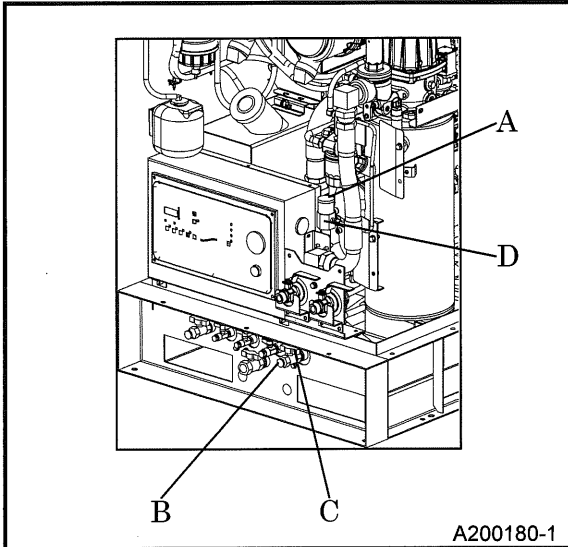

<Procedure>

1. Turn the filler cap counter-clockwise and remove the cap and dipstick [A]. Then, remove the drain plug [B] that is mounted externally and open the drain valve [C] to drain the oil.
2. When the oil is drained, close the drain valve [C], reinsert the drain plug [B] and pour in engine oil in from the engine oil filler port [D].

[Oil capacity : Approx. 1.6gal.(6.2L)]

3. Turn the filler cap [A] counter-clockwise, remove the dipstick fully, and dry it with a cloth.
4. Reinsert the dipstick fully and remove it. The amount of oil is considered normal if it is within the HIGH and LOW marks on the gauge.
5. After replenishing the oil, reinsert the filler cap [A] and hand-tighten firmly.

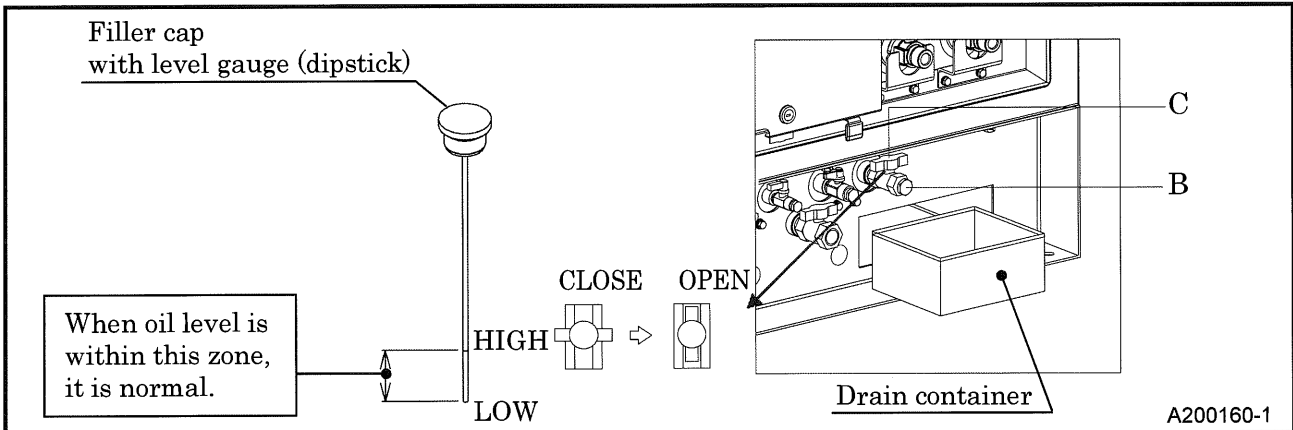

CAUTION

Caution in filling or discharging engine oil

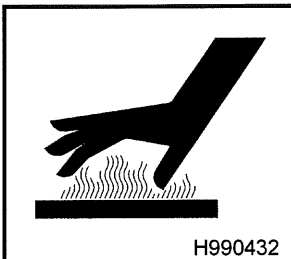

- After stopping the engine, wait of 10 minutes or more until the engine oil cools off. Then check the level of the engine oil, or refill or drain the oil.
- Engine oil is very hot and highly pressurized during and just after operating. Hot oil may spray out and cause injury.
- Never overfill the engine oil above the proper level. Too much oil can cause white smoke out of the exhaust, and it can damage and harm the engine.

IMPORTANT

- Follow the designated regulations to dispose of engine oil.

5. Periodic Inspection/Maintenance

5.4.2 Change engine oil filter element

At 50 hours for the first change and at every 250 hours thereafter

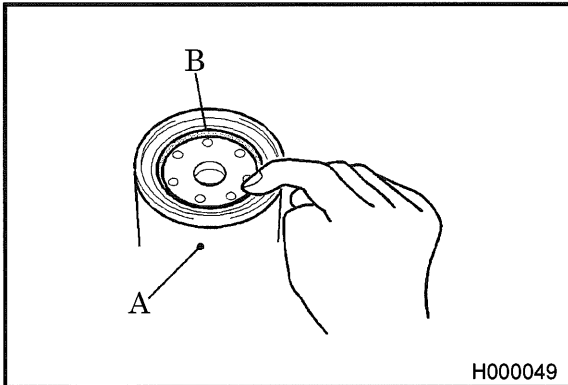

<Procedure>

1. Remove the filter [A], using a filter wrench.
2. After coating fuel on the new oil filter seal [B], screw it in. **(For part number, see 5.3)**
3. After the seal touches the sealing face, tighten another 1 times with a filter wrench.
4. After installing the oil filter, check for any leaks during operation.

5.4.3 Check battery electrolyte and specific gravity of battery electrolyte

Battery electrolyte: every 250 hours

Specific gravity of battery electrolyte: every 500 hours

If there is an engine starting issue due to battery discharge, follow the procedure below:

- Ordinary type battery:

Check the amount of battery fluid and if it is not within specification, add distilled water.

Measure specific gravity of battery electrolyte, and if it shows below 1.24, recharge the battery immediately. **(See 5.4.4)**

- Enclosed type battery:

Check the indicator on top of the battery.

If the indicator shows that charge is needed, recharge the battery immediately.

If specific gravity of battery electrolyte does not rise in spite of replenishing distilled water or charging battery, be sure to replace battery with new one quickly.

5. Periodic Inspection/Maintenance

5.4.4 Maintenance of Battery

Battery may generate hydrogen gas and can explode. Therefore, recharging should be done in a well-ventilated place.

- Do not check the battery by short-circuiting the positive and negative terminals with a piece of metal.
- Never operate the machine nor charge the batteries with the battery liquid level being kept lower than the lower level. Continuing operation at this lower level will cause deterioration of such parts as pole plates etc., and also it may cause explosion as well as reduction of battery life. Add distilled water so that the liquid level may reach the middle level between the “UPPER LEVEL” and “LOWER LEVEL” without any delay.
- Wear protective gloves and safety glasses when handling the battery.
 - When such battery electrolyte contacts your clothes or skin, wash it away with large amount of water immediately.
 - If the battery electrolyte gets into your eyes, wash it away immediately with plenty of water and see a doctor at once, because it is feared that eyesight might be lost.



WARNING Handling the Battery



D004

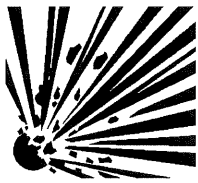

W010



TR0093

- Keep flames away from battery.
- Keep sparks, matches, cigarettes, and other fire sources away from the battery.
- Do not charge the frozen battery. Otherwise it may explode. If the battery is frozen, warm it up until the battery temperature becomes 61°F to 86°F (16°C to 30°C), and then recharge.
- Battery electrolyte is dilute sulfuric acid. In case of mishandling, it could cause skin burning.
- Dispose of battery observing local regulations.

[Charge battery]

- Use the battery charger after make sure to confirm whether it's fulfill a condition with the battery you charge.
- Disconnect the cable between battery and the machine, and charge the battery with a 12V battery charger.
- Be sure not to connect (+) and (-) terminals backwards.

5. Periodic Inspection/Maintenance

[How to use booster cable]

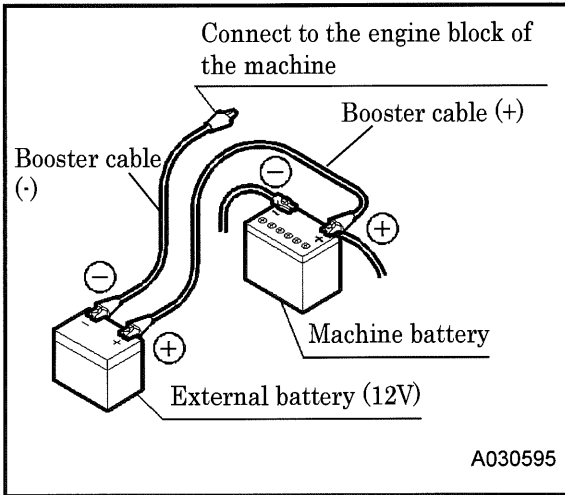

<Procedure for using a booster cable>

1. Stop the engine.
2. Connect one end of the (+) booster cable to the (+) terminal of the machine battery.
3. Connect the other end of the (+) booster cable to the (+) terminal of the external battery.
4. Connect one end of the (-) booster cable to the (-) terminal of the external battery.
5. Connect the other end of the (-) booster cable to the engine block of the machine.
6. Start up the engine.
7. Disconnect the booster cable by following the procedure back in the reverse order.



CAUTION

Do not reverse the cable connection

- When a booster cable has to be used or when cables are connected again after a battery is replaced, be careful not to connect (+) and (-) terminals backwards. Such wrong-connection will cause spark and damage to each component.

5.4.5 Check and clean clogging of air filter element

Every 250 hours

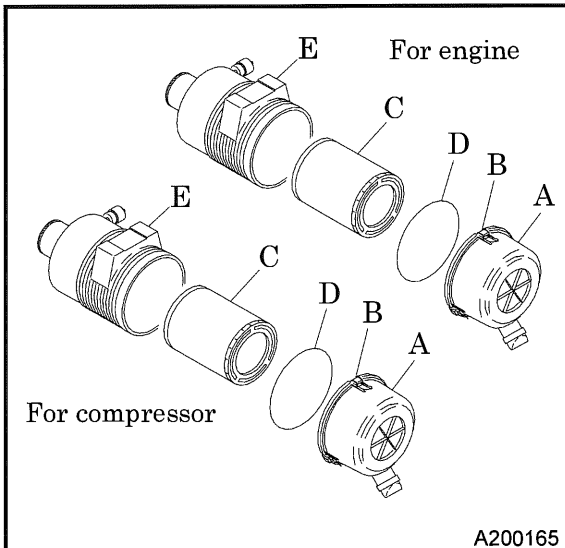

<Procedure>

1. Loosen the cap fix latch [B] at cap [A], then remove cap and clean inside.
 2. Remove the element [C], and clean it.
 3. When installing the cap after it is cleaned, hold the case [E] securely by hand so that O-ring [D] may not protrude from it, and retighten it after checking and confirming that the latch hook for fixing the cap is engaged to the case.
- If the element is found heavily dusty, replace it with a new one. **(For part number, See 5.3)**

IMPORTANT

- When an element that is clogged or has holes or cracks is used, dust or foreign material will get in the engine. This causes accelerated wear in each sliding part of the engine. Be sure to make daily check and cleaning so that the life of the engine will not be shortened.

5. Periodic Inspection/Maintenance

5.4.6 Change compressor oil

At 300 hours for the first change and at every 500 hours thereafter

- For prevention of fire caused due to deteriorated oil separator, in principle change of compressor oil is to be performed in accordance with the schedule mentioned in the regular maintenance table. However, it is heavily influenced by operation conditions and environmental conditions. If it has been found more dirty and corrupted, it should be changed.
- If machine is continuously operated in such bad conditions, it could damage bearings and degraded oil sticks oil separator to cause accumulated oxidation heat of reaction to lead oil separator fire. For this reason, regular maintenance work should be done surely and perfectly.
- Before replacing the compressor oil, stop the machine and wait for a sufficient period of time (about two or three minutes) to allow the oil to settle in the machine.

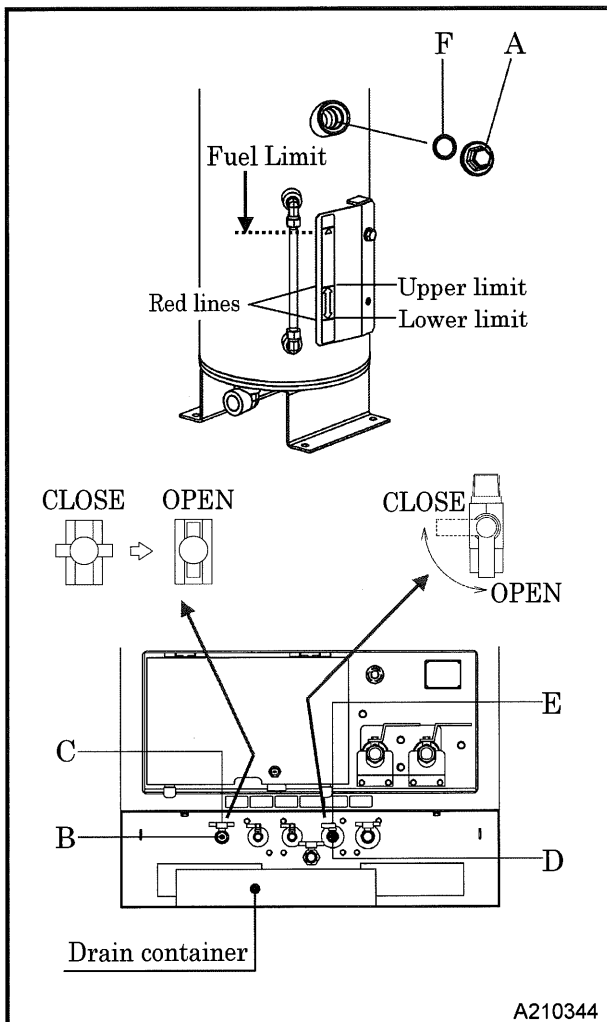

<Procedure>

1. Stop the operation of this machine. Wait until enough time has passed and for the pressure in the separator receiver tank to be completely released. Then, slowly remove the filler cap [A] and remove the drain plug [B], and then open the drain valve [C] and drain the compressor oil.
2. Remove the drain plug [D] for the oil cooler, open the drain valve [E] and drain the oil that has accumulated in the cooler into the drain container.
3. After draining compressor oil, fully close the drain valve [C] and [E]. Finally, reinsert the drain plugs [B] and [D].
4. Fill the tank with new compressor oil up to the height indicated by the dotted line (Fuel Limit). Then, close filler cap [A]. Inspect O-ring [F] of filler cap [A]. and replace it with a new one if any hardening or damage is found.
(For part number, See 5.3)
5. After starting operation, check and confirm that oil level is within red lines of oil reveal gauge.

Quantity of oil between the red lines	Approx. 0.5gal.(1.9L)
Quantity of change oil	Approx. 3.3gal.(12.5L)

IMPORTANT

- Mixture of different brands compressor oil could cause an increase of viscosity and make compressor oil sticky. In the worst case, it could cause sticking trouble of compressor air-end "Compressor air-end will not turn". Also repairing of such air-end needs expensive cost. Therefore, be sure to avoid mixing different brands oil. In case compressor oil brand in use has to be unavoidably changed, it is absolutely necessary to completely clean up the interior of compressor air-end. In such a case, contact your nearest dealer.
- Follow the designated regulations to dispose of compressor oil.

5. Periodic Inspection/Maintenance

5.4.7 Change compressor oil filter element

At 300 hours for the first change and at every 1,000 hours thereafter

Be sure to use genuine filter element.

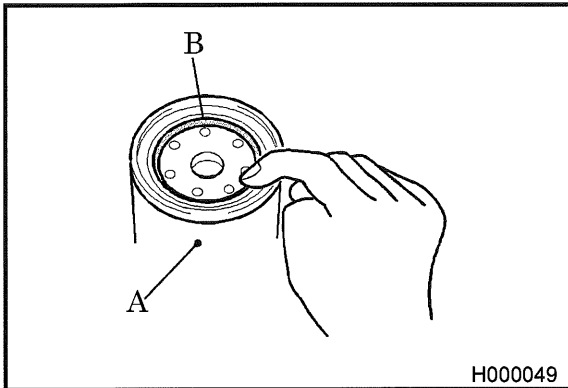

<Procedure>

1. Remove the oil filter element [A], using a filter wrench.
2. Screw in the new oil filter element [A] with the gasket [B] coated slightly with oil.
(For part number, See 5.3)
3. After the gasket touches the sealing face, tighten another 3/4 to 1 turn with a filter wrench.
4. After installing the oil filter element, check it for any leak during operation.

IMPORTANT

- Poor quality oil filter element do not trap dust sufficiently and will cause damage to the bearings in a short period. Be sure to use genuine parts.

5.4.8 Change air filter element

Every 500 hours

Be sure to use genuine air filter element.

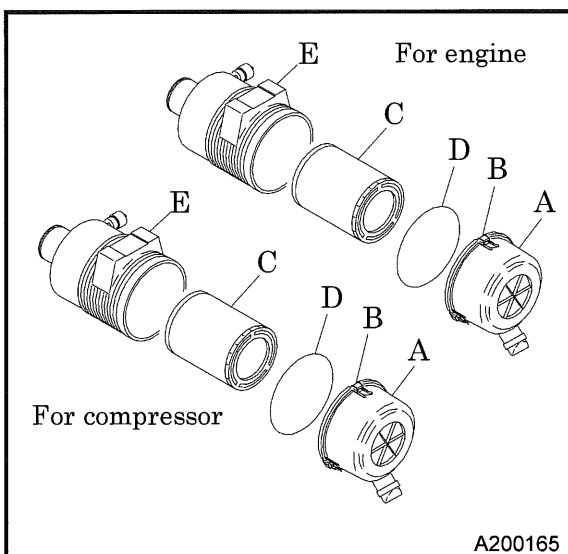

<Procedure>

1. Loosen the cap fix latch [B] at cap [A], then remove cap and clean inside.
 2. Remove element [C] and replace with new one.
(For part number, See 5.3)
 3. When installing the cap, surely push the O-ring [D] to the case [E] with a hand and then tighten it after checking and confirming that the hook of the cap fixing latch is caught in the case.
- When used or operated under bad conditions, it is better to remove all the elements, check them, clean them and replace them earlier before the intervals listed in maintenance table, if they are found difficult to be repaired.

IMPORTANT

- The air filter is an important part which is crucial to your machine's performance and life. Be sure to use genuine parts.

5. Periodic Inspection/Maintenance

5.4.9 Clean strainer in the scavenging orifice

Every 500 hours

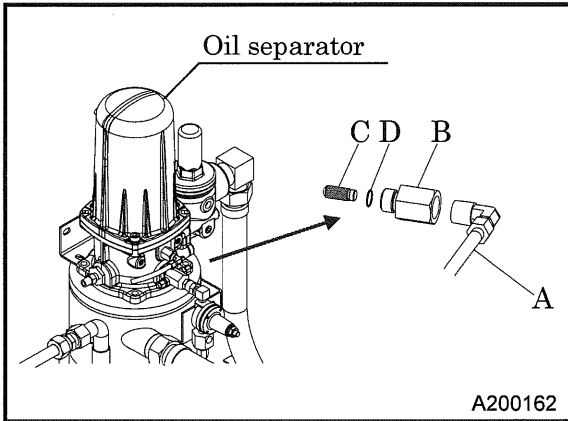

<Procedure>

1. Remove the pipe [A].
 2. First remove the bushing [B].
 3. Then remove the strainer [C].
 4. Wash the removed strainer in diesel oil and blow out "dust" by air blowing.
 5. After finishing the cleaning, install the strainer again in the reverse procedure.
- When cleaning, inspect the O-ring [D] on the bushing [B]. If the O-ring [D] is hardened or damaged, replace it with a new one.

5.4.10 Change of fuel filter element

Every 500 hours

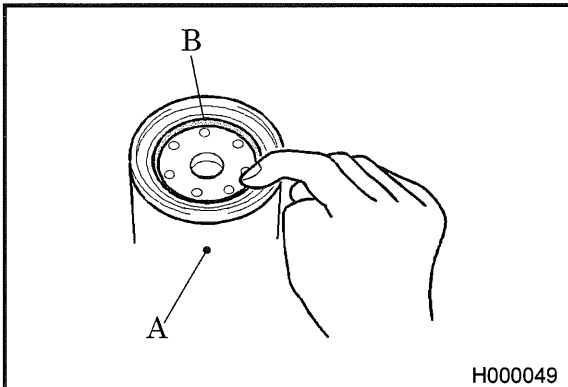

<Procedure>

1. Remove the fuel filter element [A], using a filter wrench.
2. Screw in the new fuel filter element [A] with the gasket [B] coated slightly with oil.
(For part number, See 5.3)
3. After the gasket touches the sealing face, tighten it by turning 1 times using a filter wrench.
4. After installing a fuel filter element in position, be sure to check for oil leakage during operation.

5. Periodic Inspection/Maintenance

5.4.11 Change of element inside fuel pre-filter

Every 500 hours

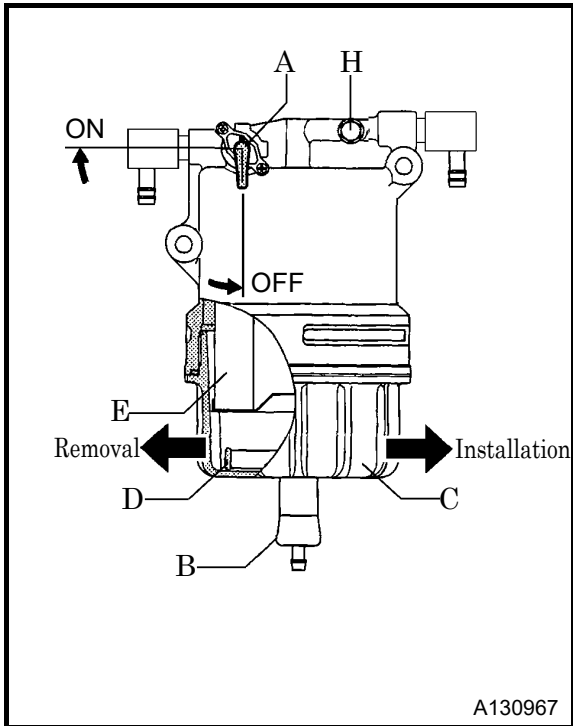

<Procedure>

1. Turn fuel selector valve [A] to [OFF] position.
 2. Loosen the drain valve [B] and drain out condensed water inside.
 3. Turn the cup [C] to the left and remove it. Be careful to remove the cup [C], because it is filled with fuel. Wipe out split fuel completely.
 4. Remove float [D] inside cup [C].
 5. Replace element [E] and clean the inside of the cup [C] with new fuel.
 6. Inspect the O-ring. If it is hardened or damaged, replace it with a new one. **(For part number, See 5.3)**
 7. After finishing Change, assemble it in reverse procedure.
- If air is found still in fuel pipe, place control power switch to the  position and loosen air bleeding bolt [H] to bleed air.
 - Drain the condensate in container, and then dispose of condensate according to the designated regulations.

5.4.12 Clean exterior of the radiator · oil cooler

Every 1,000 hours

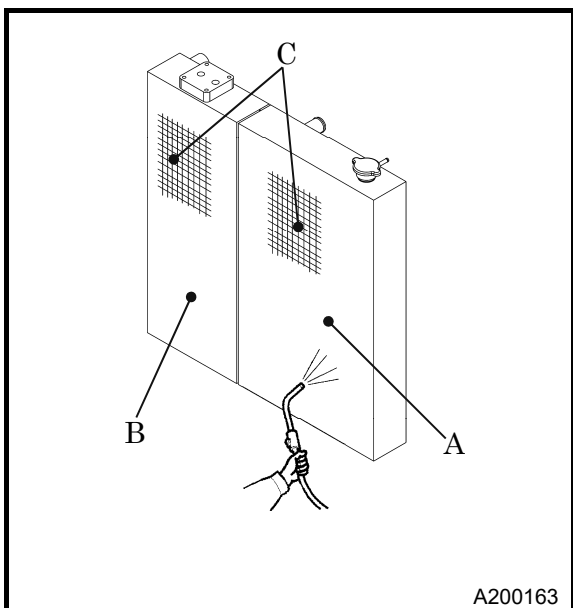

- When the fin tubes diaphragm [C], of a radiator [A], and an oil cooler [B] are clogged with dust or other foreign materials, the heat exchange efficiency drops and this will raise coolant temperature and discharge air temperature. These tubes and fins should be cleaned depending on the state of clogged tubes diaphragm, even before maintenance schedule.
- Do not use a high pressure washer, in order to protect the fin tubes from being damaged.
- Take steam cleaning with removing cooler when there is a lot of dirt.
- When cleaning it, contact your nearest dealer.

5. Periodic Inspection/Maintenance

5.4.13 Clean interior of radiator

Every 1,000 hours

- When the inside of a radiator and water conduits of an engine are dirty with scale and rust, its cooling efficiency will be deteriorated. Clean the interiors of such components periodically.
- When cleaning it, contact your nearest dealer because it requires expert technical knowledge.

5.4.14 Clean the oil fence and check for rust

Every 1,000 hours

Expert knowledge is required to clean the inside of the oil fence and to check it for rust. Contact your nearest dealer.

5.4.15 Change oil separator element

2,000 hours or every 2 years

- If there is a large amount oil in the service air and the unit is also consuming a large volume of compressor oil, it may be necessary to replace the oil separator element with a new one before the scheduled maintenance.

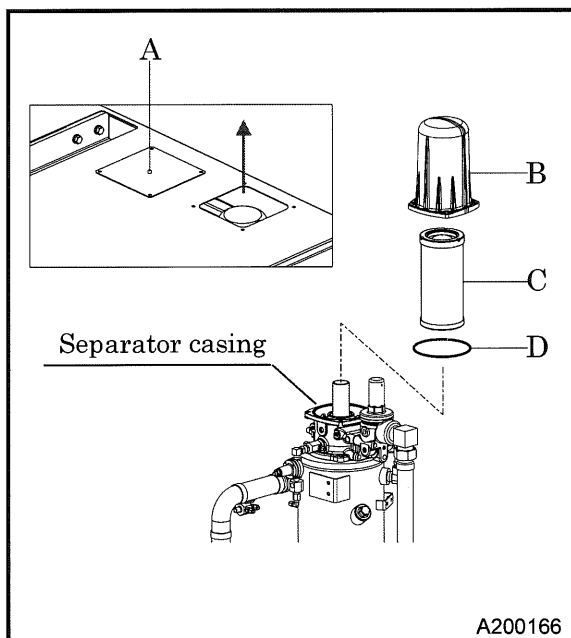

<Procedure>

1. To pull out the separator element, remove the inspection cover [A] on the top cover.
 2. Remove separator cover [B] bolts 4 pieces.
 3. Replace element [C] and O-ring [D] by a new one.
 4. After installing the element, check it for any leak during operation.
- When consumption of the oil is still unusual even after cleaning strainer in the scavenging orifice (See 5.4.9), change the oil separator element with a new one. **(For part number, See 5.3)**
 - When replacing oil separator, contact your nearest dealer because it requires expert technical knowledge.

5.4.16 Clean inside of fuel tank

Every 2,000 hours

When cleaning inside of fuel tank it, contact your nearest dealer because technical knowledge is required.

5. Periodic Inspection/Maintenance

5.4.17 Change coolant (LLC)

2,000 hours or every 2 years

Be sure to stop the engine and let the coolant water sufficiently cool down before changing it.

<Procedure>

1. Remove the water filler cover [A] at the top of the radiator and the radiator cap [B]. Then, remove the drain plug [C] at the bottom part of the operation panel, open the drain valve [D], and drain the cooling water.
 2. Be sure to also open the drain plug [E] on the engine cylinder block for drainage.
(Prepare something to drain into before starting drainage.)
 3. Drain the coolant in the reserve tank.
 4. When cooling water is drained, close the drain valve [D], mount the drain plug [C] and tighten the drain plug [E] on the engine cylinder block. Insert cooling water up to the mouth of the water filler port of the radiator. Do not forget to pour in cooling water up to the MAX level of the reserve tank.
 5. After refilling coolant, securely attach the radiator cap [A] and the reserve tank cap and operate the machine for about 2-3 minutes with no load.
- Refer to section 3.3.2 for reserve tank capacity details.

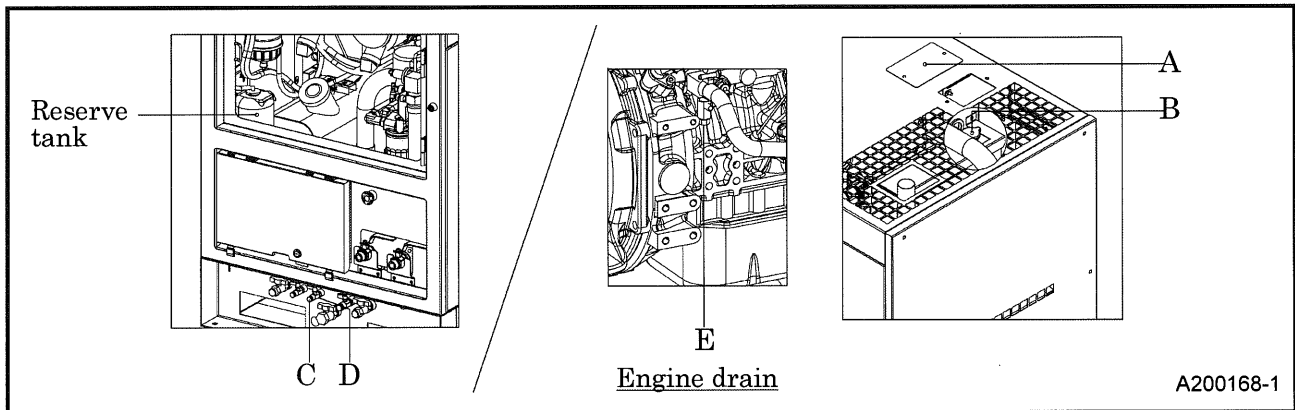

CAUTION Caution when changing coolant

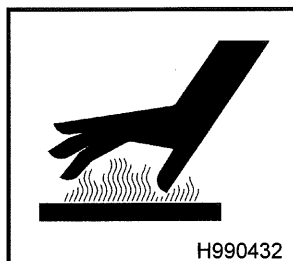

- When removing the radiator cap, lightly turn it and release the internal pressure without completely opening it once the first stage lock is released. After confirming that the internal pressure has been released, turn it while pushing in until the second stage lock is released. If this procedure is neglected, its inner pressure can blow off the radiator cap, and steam jetting out of the radiator may cause scalding burns.
- LLC (Antifreeze) is a toxic.
- In case of accidental ingestion, do not force vomiting and seek medical attention immediately.
- In case of contact with eyes, rinse with plenty of water and seek medical attention.
- When storing LLC (antifreeze), label it as LLC (antifreeze), seal it, and keep it out of reach of children.
- Beware of flames.

IMPORTANT

- Follow the designated regulations to dispose of LLC (Antifreeze).

5. Periodic Inspection/Maintenance

5.4.18 Change nylon tubes

2,000 hours or every 2 years

Replace nylon tubes used for the oil and air piping's. When replacing it, contact your nearest dealer because technical knowledge is required.

5.4.19 Change fuel hose

2,000 hours or every 2 years

In case various rubber hoses for fuel system and engine lubrication system are hardened or deteriorated, replace them even before the specified replacement time.

When replacing hoses, contact your nearest dealer because it requires expert technical knowledge.

5.4.20 Change solenoid valve for starting unload

Every 3,000 hours

When replacing it, contact your nearest dealer because it requires expert technical knowledge.

5.4.21 Change rubber hose

3,000 hours or every 3 years

Check hoses used for oil piping for any crack or tear, and replace when an abnormality is found.

When replacing hoses, contact your nearest dealer because it requires expert technical knowledge.

5.4.22 Change O-ring of unloader

3,000 hours or every 3 years

When replacing it, contact your nearest dealer because it requires expert technical knowledge.

5. Periodic Inspection/Maintenance

5.4.23 Change radiator hoses

3,000 hours or every 3 years

When any crack or wear is found on the hoses, change it even before the scheduled time.
When replacing it, contact your nearest dealer because it requires expert technical knowledge.

5.4.24 Change pressure regulator

3,000 hours or every 3 years

When replacing it, contact your nearest dealer because it requires expert technical knowledge.

(For part number, See 5.3)

5.4.25 Check that the pressure control valve is working and replace any consumables

3,000 hours or every 3 years

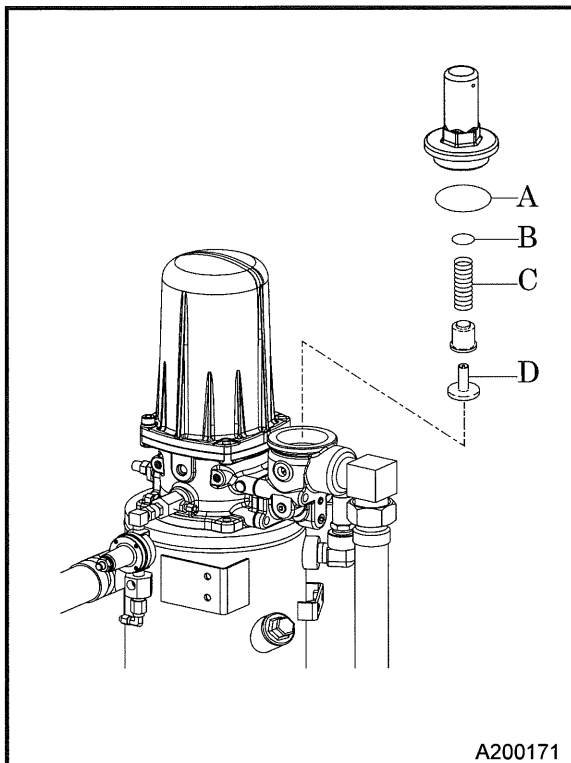

<Procedure>

1. When the service valve is fully opened during operation, confirm that the pressure gauge on the operation panel indicates 49 to 68 psi (3.4 to 4.7 bars).
 2. When the pressure is lower than 49psi (3.4bar), replace spring [C] with a new one.
(For part number, See 5.3)
 3. When the indicator shows excessively higher pressure, you will find that the piston does not move smoothly due to foreign material and rust stuck inside valve. In such a case, disassemble the component for checking and cleaning.
- When replacing it, contact your nearest dealer because it requires expert technical knowledge.

IMPORTANT

- When reassembling, apply sufficient grease to O-ring Slot/O-ring and sliding surface.
Use CALTEX MULTIFAK EP1 grease or equivalent. Grease of poor quality will deteriorate the material.

5. Periodic Inspection/Maintenance

5.4.26 Check O-ring and piston of pressure control valve

3,000 hours or every 3 years

After disassembling and cleaning pressure control valve, check O ring [A], [B] and piston [D]. When the rubber of these parts is found hardened, or damaged, replace them. **(For part number, See 5.3)** When replacing it, contact your nearest dealer because it requires expert technical knowledge.

5.4.27 Inspections and replacements of consumables for the auto relief and vacuum relief valves

3,000 hours or every 3 years

For these particular inspections and replacements, contact your nearest dealer, as doing this requires expert technical knowledge. If the rubber is hardened, replace it with a new one.

5.4.28 Change oil seal/bearing

Every 8,000 hours

When replacing it, contact your nearest dealer because it requires expert technical knowledge.

6. Storage and Disposal

6.1 Preparation for Long-term Storage

When storing for more than half a year without using the machine, perform the following measures and store it in a dry place with little dust.

- Put the machine in a temporary cabin if it is stored outside. Avoid leaving the machine outside with a sheet directly on the paint for a long period of time, as this may cause rusting.
- Perform the following measures at least once every three months.

<Procedure>

1. Drain existing lubricant from the engine oil pan. Pour new lubricant in the engine to clean the internals of the engine. After running it for a while, drain it again.
2. Completely charge the battery and disconnect grounding wires. If possible, remove the battery from the machine and store it in a dry place. (Charge the battery at least once every month.)
3. Drain coolant and fuel from the machine.
4. Seal the engine, air-intake port and other openings like the muffler with a vinyl sheet, packing tape, etc., to prevent moisture and dust from entering the machine.
5. Be sure to repair any breakdowns and maintain the machine so that it will be ready for the next operation.

6.2 Disposal of Product

When disposing of this machine, first drain the cooling water and oils.
If you require any additional information, contact your nearest dealer.

7. Specifications

7.1 Specifications

Model		PDS185L-5E1		
COMPRESSOR	Type		Single-stage oil cooled, screw type compressor	
	Free air delivery	cfm(m ³ /min)	185(5.2)	
	Working pressure	psi(bar)	100(6.9)	
	ENG.SPEED (full load)	min ⁻¹	3,000	
	ENG.SPEED (unload)	min ⁻¹	1,350	
	Lubricating system		Forced Lubrication by compressed pressure	
	Driving system		Direct driving with gear coupling	
	Receiver tank capacity	cu in.(L)	1,159(19.0)	
	Lubricating oil capacity	gal.(L)	3.3(12.5)	
ENGINE	Model		YANMAR 4TNV88C-DHKS1	
	Type		Water-cooled 4-cycle direct injection	
	Cylinder quantity · Cylinder diameter × Cylinder stroke	in(mm)	4·3.46in×3.54in(4·88mm×90mm)	
	Total displacement	cu in.(L)	133.6(2.189)	
	Rated output (GROSS)	kW/min ⁻¹	35.5/3,000	
	Rated output (NET)	kW/min ⁻¹	34.0/3,000	
	Lubricating oil capacity	gal.(L)	Lubricating oil capacity: 1.95(7.4)	
			Quantity of change oil: 1.6(6.2)	
	Coolant capacity (including radiator)	gal.(L)	2.88(10.9)	
	Battery		95D31R(12V)	
Fuel tank capacity	gal.(L)	23.2(88.0)		
Dimension · mass	Overall length	in(mm)	79.6(2,022)	
	Overall length (only for bonnet)	in(mm)	78.8(2,000)	
	Overall width	in(mm)	33(838)	
	Overall height	in(mm)	45.7(1,160)	
	Net dry mass	lb(kg)	1,720(780)	
	Operating mass	lb(kg)	1,940(880)	
OTHERS	The capacity of oil fence	gal.(L)	33(125)	

7. Specifications

7.2 Exterior drawing

Unit : in.

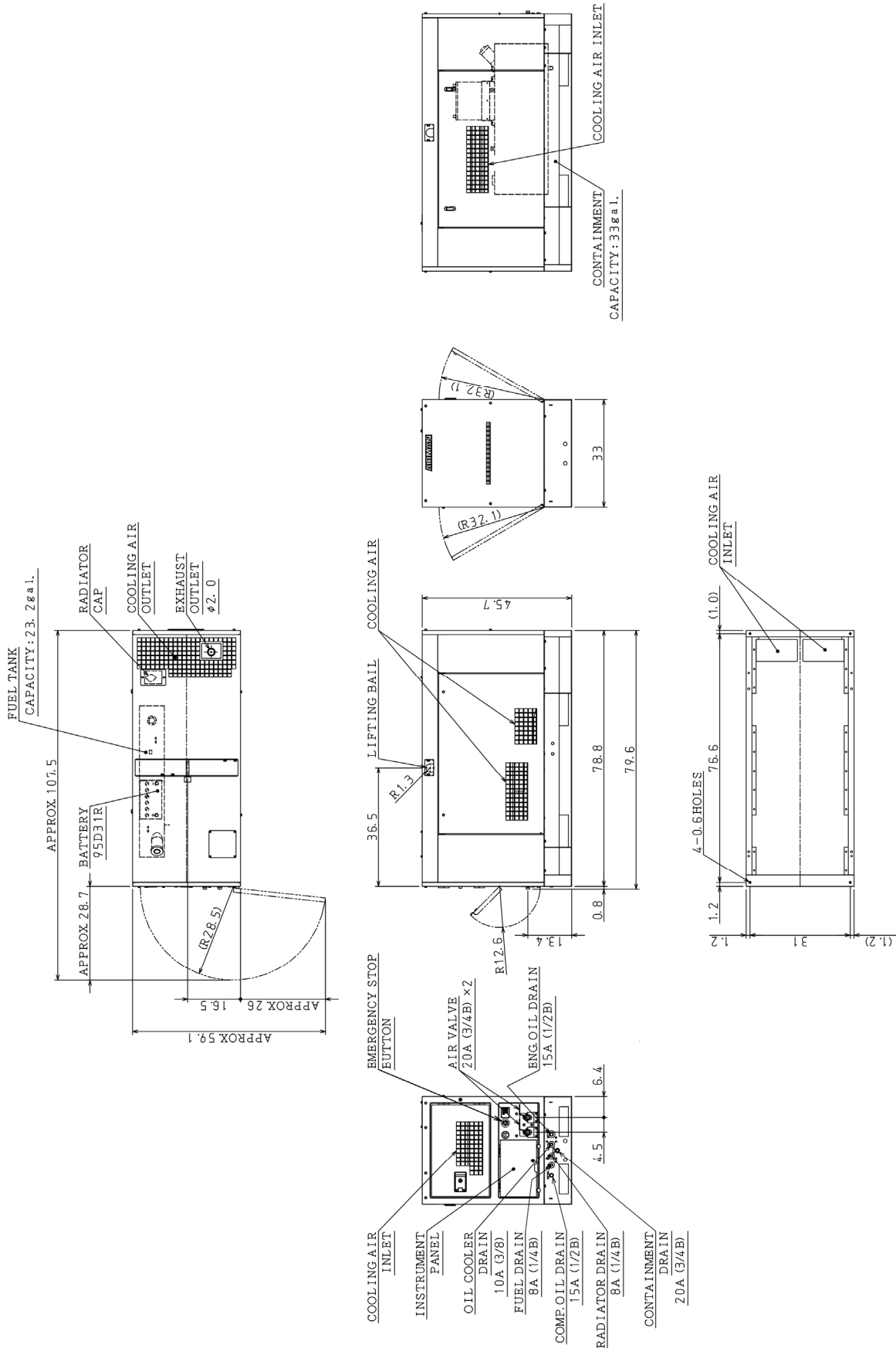

A20017E-2

7. Specifications

Unit : mm

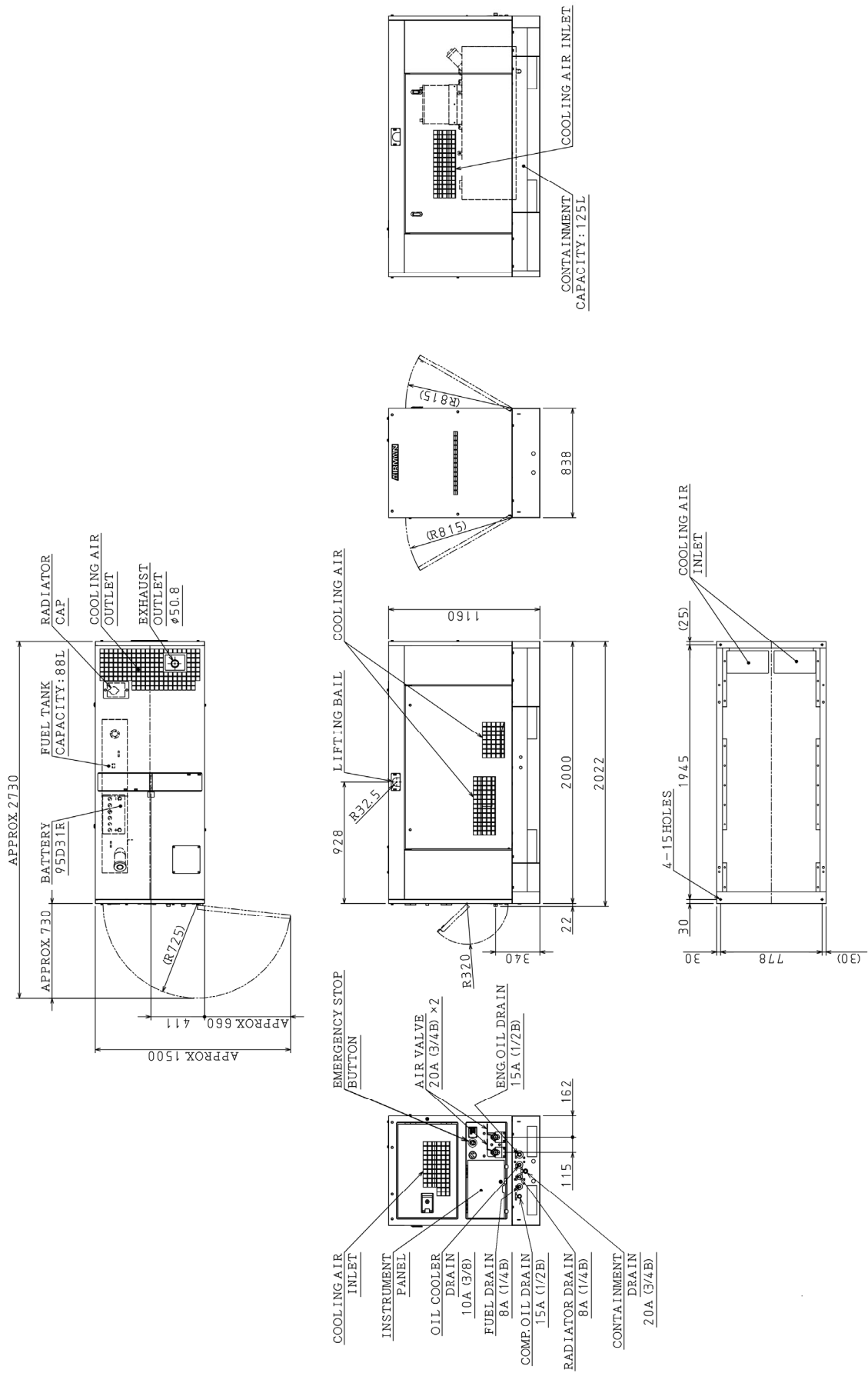

A200178E-2

7. Specifications

7.3 Wiring Diagram

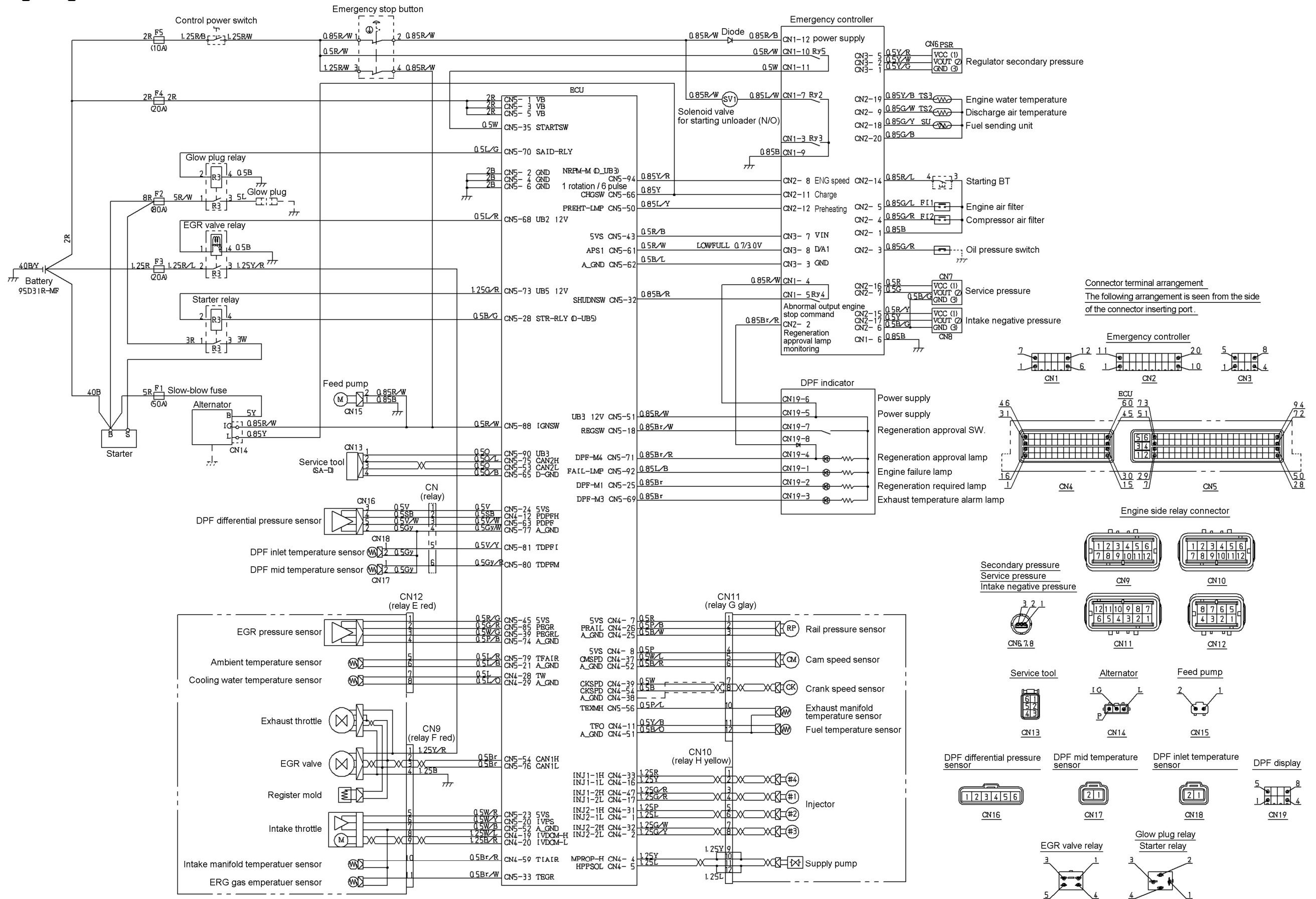

7. Specifications

7.4 Piping Diagram

7.4.1 Compression air · Compressor oil

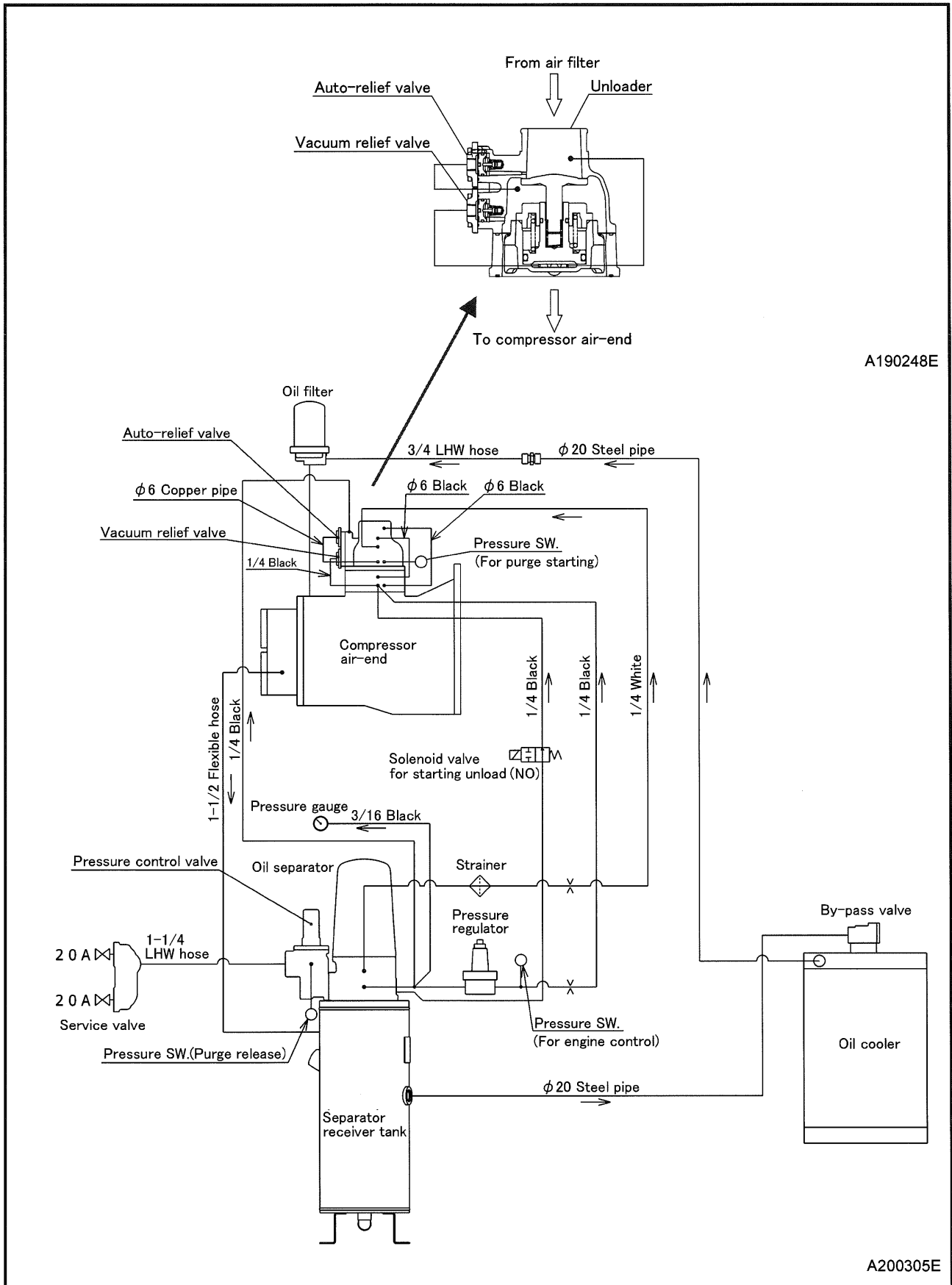

7. Specifications

7.4.2 Fuel Piping

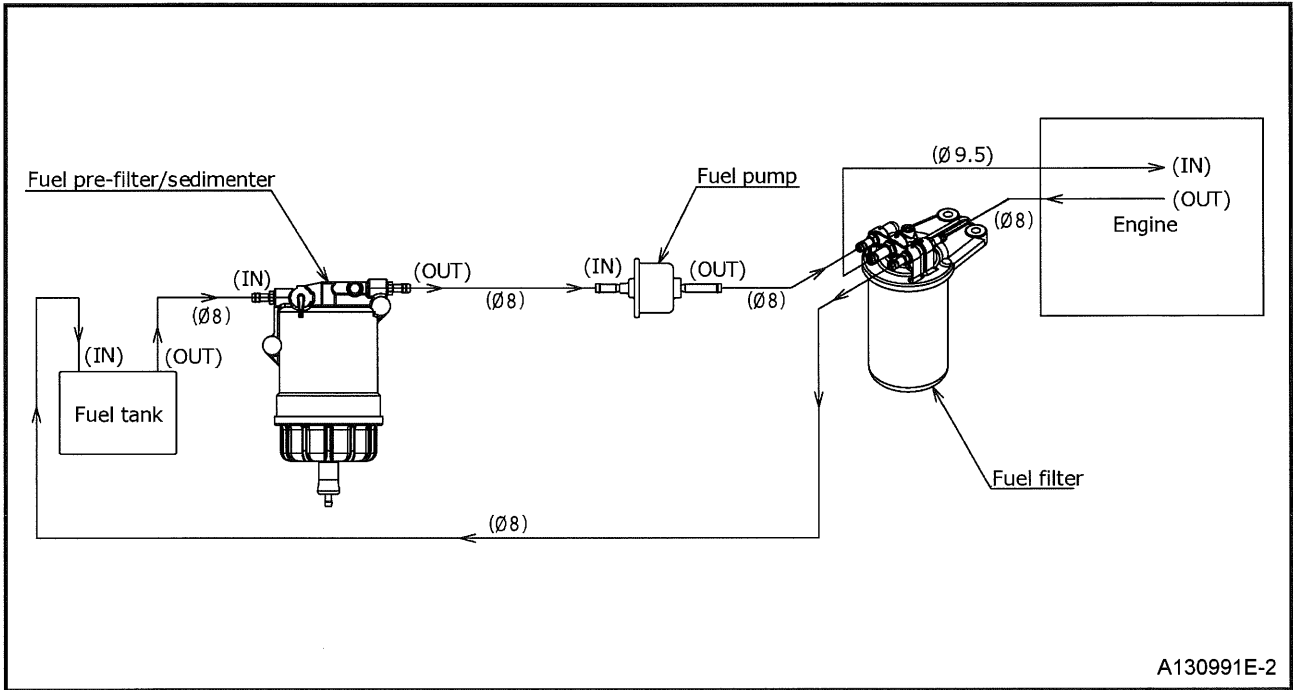

8.Emission System Warranty

This machine is equipped with a YANMAR engine. Emission system warranties are as follows:

EMISSION SYSTEM WARRANTY

YANMAR POWER TECHNOLOGY CO., LTD.

LIMITED EMISSION CONTROL SYSTEM WARRANTY – USA ONLY

Your Warranty Rights and Obligations:

The California Air Resources Board (CARB), the United States Environmental Protection Agency (EPA) and YANMAR POWER TECHNOLOGY CO., LTD. hereafter referred to as YANMAR, are pleased to explain the emission control system warranty on your 2023, 2024, or 2025 model year compression-ignition engine. In California, new heavy-duty off-road engines must be designed, built and equipped to meet the State's stringent anti-smog standards. In the remaining forty nine (49) states, new non-road compression-ignition engines must be designed, built and equipped to meet the United States EPA emissions standards. YANMAR must warrant the emission control system on your engine for the periods of time listed below provided there has been no abuse, neglect or improper maintenance of your engine.

Your emission control system may include parts such as the fuel injection system, the air induction system, the electronic control system, EGR (Exhaust Gas Recirculation) system and the exhaust gas after treatment (diesel particulate filter system, urea SCR system). Also included may be hoses, belts, connectors and other emission-related assemblies.

Where a warrantable condition exists, YANMAR will repair your heavy-duty off-road compression-ignition engine at no cost to you including diagnosis, parts and labor.

Manufacturer's Warranty Coverage:

2023, 2024, or 2025 model year heavy-duty off-road compression-ignition engines are warranted for the periods listed below. If any emission-related part on your engine is defective, the part will be repaired or replaced by YANMAR.

If your engine is certified as	And its maximum power is	And its rated speed is	Then its warranty period is
Variable speed or constant speed	kW < 8	Any speed	2,000 hours or two (2) years whichever comes first. In the absence of a device to measure the hours of use, the engine has a warranty period of two (2) years.
Variable speed or constant speed	8 ≤ kW < 19	Any speed	2,000 hours or two (2) years whichever comes first. In the absence of a device to measure the hours of use, the engine has a warranty period of two (2) years.
Constant speed	19 ≤ kW < 37	3,000 rpm or higher	2,000 hours or two (2) years whichever comes first. In the absence of a device to measure the hours of use, the engine has a warranty period of two (2) years.
Constant speed	19 ≤ kW < 37	Less than 3,000 rpm	3,000 hours or five (5) years whichever comes first. In the absence of a device to measure the hours of use, the engine has a warranty period of five (5) years.
Variable speed	19 ≤ kW < 37	Any speed	3,000 hours or five (5) years whichever comes first. In the absence of a device to measure the hours of use, the engine has a warranty period of five (5) years.
Variable speed or constant speed	kW ≥ 37	Any speed	3,000 hours or five (5) years whichever comes first. In the absence of a device to measure the hours of use, the engine has a warranty period of five (5) years.

8.Emission System Warranty

Emission control system warranty – continued

Warranty Coverage:

This warranty is transferable to each subsequent purchaser for the duration of the warranty period. YANMAR recommends that repair or replacement of any warranted part will be performed at an authorized YANMAR dealer.

Warranted parts not scheduled for replacement as required maintenance in the owner's manual shall be warranted for the warranty period. Warranted parts scheduled for replacement as required maintenance in the owner's manual are warranted for the period of time prior to the first scheduled replacement. Any warranted parts scheduled for replacement as required maintenance that are repaired or replaced under warranty shall be warranted for the remaining period of time prior to the first scheduled replacement. Any part not scheduled for replacement that is repaired or replaced under warranty shall be warranted for the remaining warranty period.

During the warranty period, YANMAR is liable for damages to other engine components caused by the failure of any warranted part during the warranty period.

Any replacement part which is functionally identical to the original equipment part in all respects may be used in the maintenance or repair of your engine and shall not reduce YANMAR's warranty obligations. Add-on or modified parts that are not exempted may not be used. The use of any non-exempted add-on or modified parts shall be grounds for disallowing a warranty.

Warranted Parts:

This warranty covers engine components that are a part of the emission control system of the engine as delivered by YANMAR to the original retail purchaser. Such components may include the following:

- Fuel injection system (including Altitude compensation system)
- Cold start enrichment system
- Intake manifold and Air intake throttle valve
- Turbocharger systems
- Exhaust manifold and exhaust throttle valve
- Positive crankcase ventilation system
- Charge Air Cooling systems
- Exhaust Gas Recirculation (EGR) systems
- Exhaust gas after treatment (Diesel Particulate Filter (DPF) system, urea SCR system)
- Electronic Control units, sensors, solenoids and wiring harnesses used in above systems
- Hoses, belts, connectors and assemblies used in above systems
- Emission Control Information Labels

Since emissions related parts may vary slightly between models, certain models may not contain all of these parts and other models may contain the functional equivalents.

8.Emission System Warranty

Emission control system warranty – continued

Exclusions:

Failures other than those arising from defects in material or workmanship are not covered by this warranty. The warranty does not extend to the following: malfunctions caused by abuse, misuse, improper adjustment, modification, alteration, tampering, disconnection, improper or inadequate maintenance, or use of non-recommended fuels and lubricating oils; accident-caused damage and replacement of expendable items made in connection with scheduled maintenance. YANMAR disclaims any responsibility for incidental or consequential such as loss of time, inconvenience, loss of use of equipment/engine or commercial loss.

Owner's Warranty Responsibilities:

As the off-road compression-ignition engine owner, you are responsible for the performance of the required maintenance listed in your owner's manual. YANMAR recommends that you retain all receipts, covering maintenance on your off-road compression-ignition engine, but YANMAR cannot deny warranty solely for the lack of receipts or for your failure to ensure the performance of all scheduled maintenance.

As the off-road engine owner, you should however be aware that YANMAR may deny your warranty coverage if your off-road compression-ignition engine or a part has failed due to abuse, neglect, improper maintenance or unapproved modifications.

Your engine is designed to operate on diesel fuel only. Use of any other fuel may result in your engine no longer operating in compliance with California's and EPA's emissions requirements.

You are responsible for initiating the warranty process. The ARB and EPA suggest that you present your off-road engine to a YANMAR dealer as soon as a problem exists. The warranty repairs should be completed by the dealer as expeditiously as possible. If you have any questions regarding your warranty rights and responsibilities, you should contact YANMAR America Corporation. If you would like to find the nearest YANMAR dealer or authorized service center, you should contact YANMAR America Corporation.

Website: <https://www.yanmar.com>

E-mail: CS_support@yanmar.com

Toll free telephone number: 1-800-872-2867, 1-855-416-7091

What the Emergency Stationary Type Engine Owner must Do:

The engines for emergency stationary type generators certified by Federal Law (40 CFR Part 60) are limited to emergency use only, and the operation for maintenance checks and verification test for functions is required. The total operating hours for maintenance and verification test for functions should not exceed 100 hours per year. However, there is no limitation on the operating hours for emergency use. Keep a log of the number of hours the engine is operated for both emergency use and non-emergency use. Also, note the reason for the operation.

HOKUETSU INDUSTRIES CO., LTD.

8TH FLOOR SHINJUKU SAN-EI BLDG,
22-2 NISHI-SHINJUKU 1-CHOME, SHINJUKU-KU
TOKYO 160-0023 JAPAN
TEL:81-3-3348-7281
FAX:81-3-3348-7289
URL:<http://www.airman.co.jp>

Copyright (C) 2023 HOKUETSU INDUSTRIES CO., LTD. All Rights Reserved.

39600 57150

Printed DEC. 2023

AIRMAN
HOKUETSU INDUSTRIES CO., LTD.